







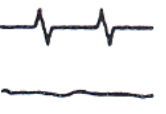

# **CVIČENÍ 1**

## **DRUHY ČAR A TECHNICKÉ PÍSMO**

## DRUHY ČAR V TECHNICKÉM KRESLENÍ

Druhy čar	Zobrazení	Základní význam a příklady použití
plná pravidelná		viditelné zaoblené a neurčité hrany a průniky; kólovací, pomocné a odkazové čáry (včetně praporků); palní kružnice a přímky, elektrická vedení ohcně, pomocné obvody, apod.
		viditelné obrysy a hrany předmětů zobrazených v pohledu nebo, elektrická spojení s funkčním významem, hlavní obvody, přípojnice, přípojnicové rozvody, svazky vodičů, vymezení kreslicí plochy výkresu, apod.
		lepený spoj; svazky kabelů, vedení při potřebě rozlišení různých druhů, apod.
plná nepravidelná		přerušeni obrazů, rozhraní mezi pohledem a řezem u částečných řezů, ukončení částečně nakresleného obrazu, apod.
čárkovaná		zakryté (neviditelné) obrysy a hrany; hydraulická spojení, stínění, apod.
čerchovaná		poloha myšlených rovin řezu, nelze-li použít tlusté úsečky označující rovinu řezů, apod.
		osy souměrnosti, roztečné přímky a kružnice, dělicí čáry mezi zařízeními v poli rozvaděčů, ohraničení souboru přístrojů nebo prvků tělož přístroje, ochranný vodič uzemňovací pro chlazený rozvod, apod.
čerchovaná se dvěma tečkami		označení místa ohybu, krajní polohy pohyblivých částí, těžištní osa, zobrazení původního, resp. konečného tvaru, apod.
tečkovaná		pokračování, resp. opakování prvků nebo obvodů, podružné a vedlejší obrysy apod.

### KŘÍŽENÍ A NAVAZOVÁNÍ ČÁRKOVANÝCH A ČERCHOVANÝCH ČAR

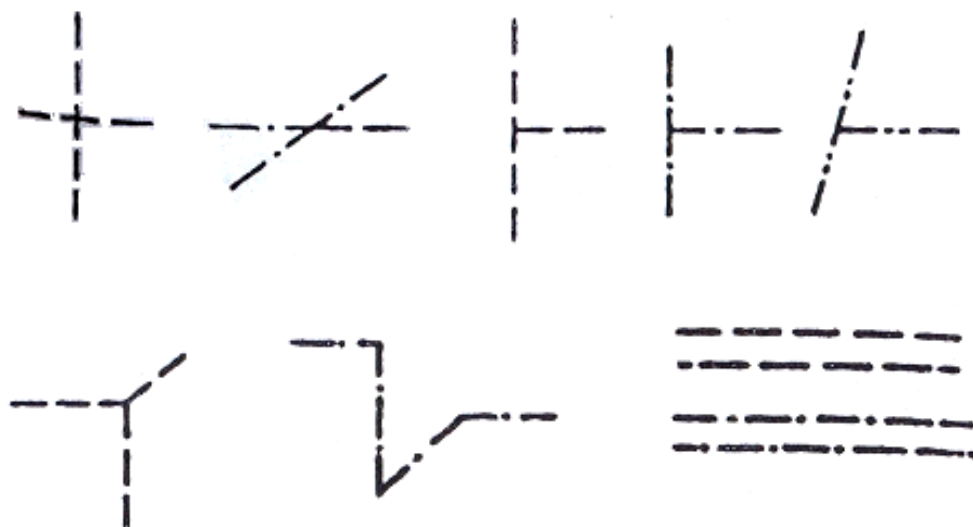



TECHNICKÉ PÍSMO

A B C D E F G H I J K L M N

O P Q R S T U V W X Y Z

a b c d e f g h i j k l m n o p

q r s t u v w x y z č ě é ě í

1 2 3 4 5 6 7 8 9 0 č é ě í

α β γ δ ε ζ η θ ι κ λ μ

ν ξ ο π ρ σ τ υ φ χ ψ ω



## PŘÍKLADY NÁKRESŮ NA PROCVIČENÍ ČAR

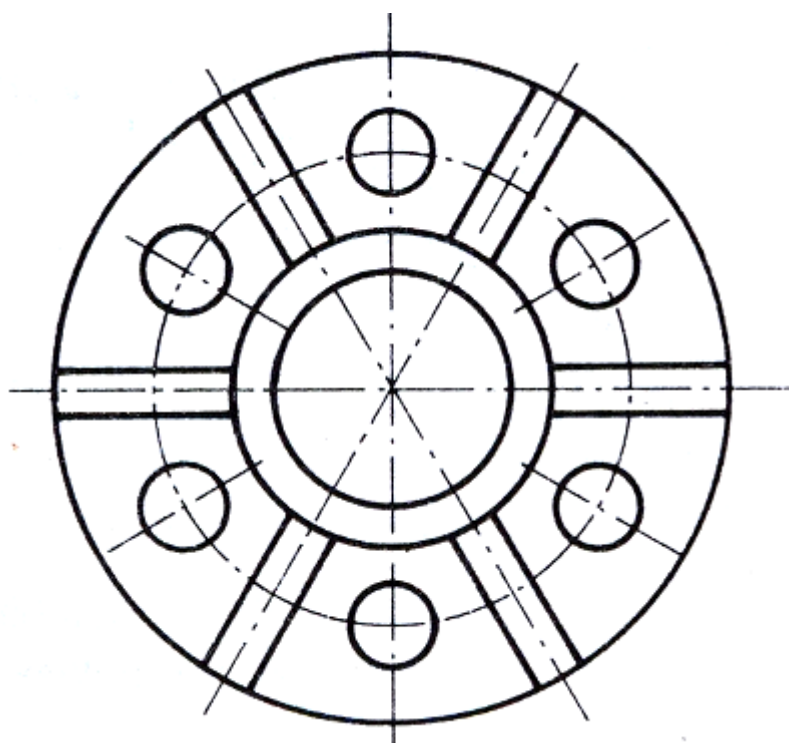
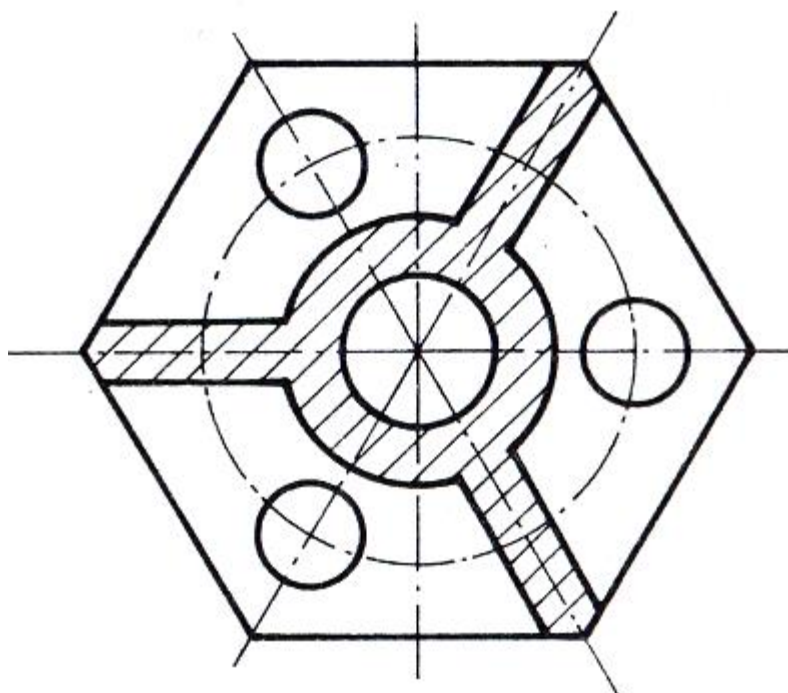



## PŘÍKLADY NÁKRESŮ NA PROCVIČENÍ ČAR

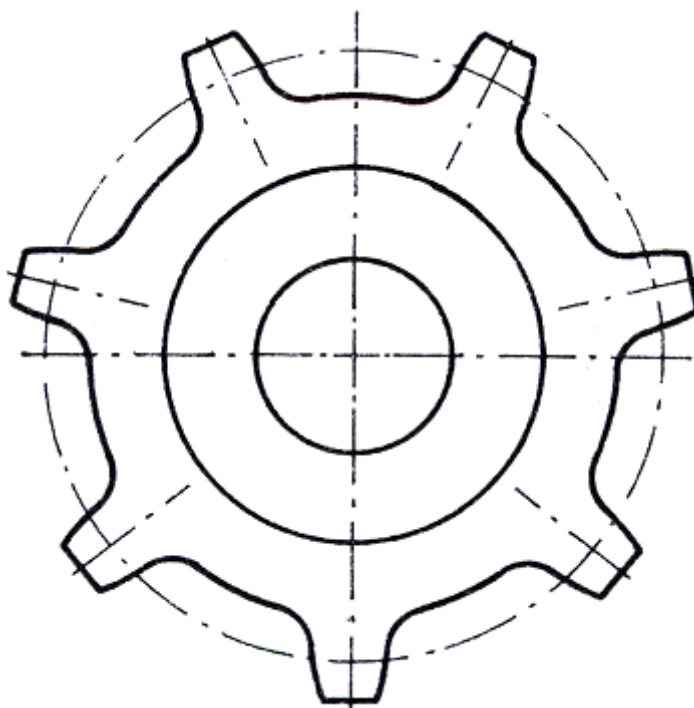
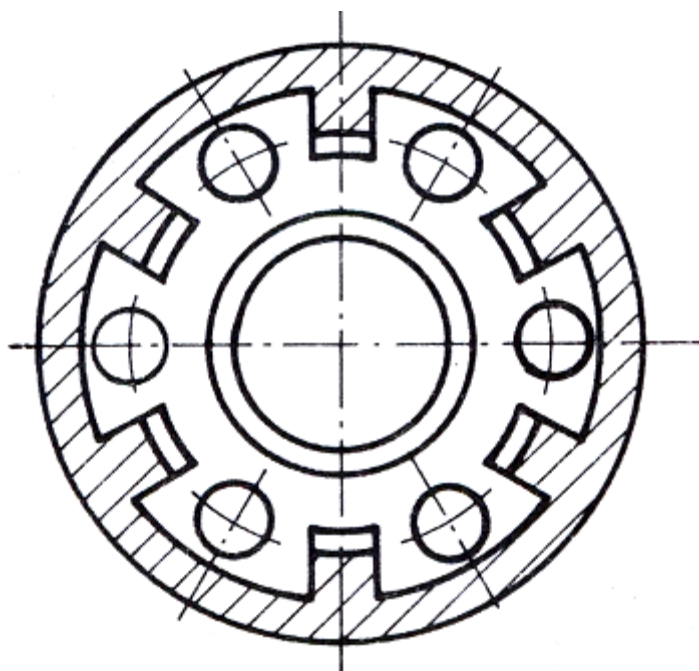

## **CVIČENÍ 2**

# **PRAVOÚHLÉ PROMÍTÁNÍ**

## Metoda promítání v prvním kvadrantu

*značka metody  
promítání 1*

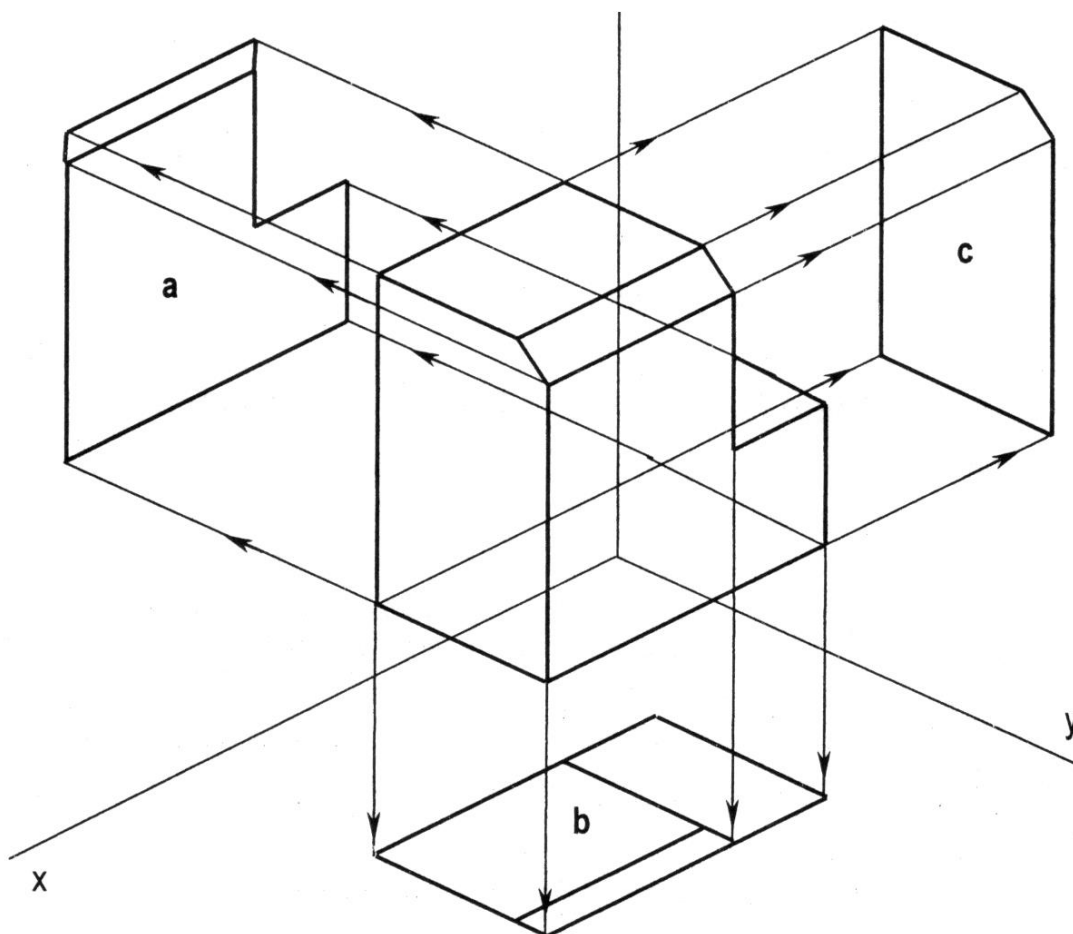
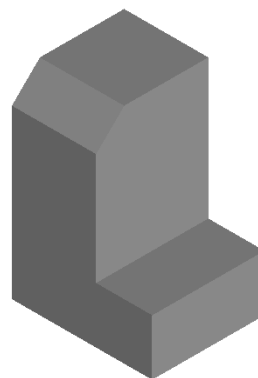
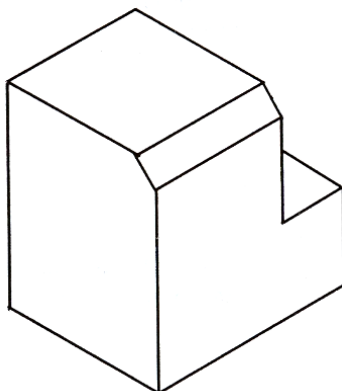
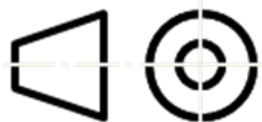



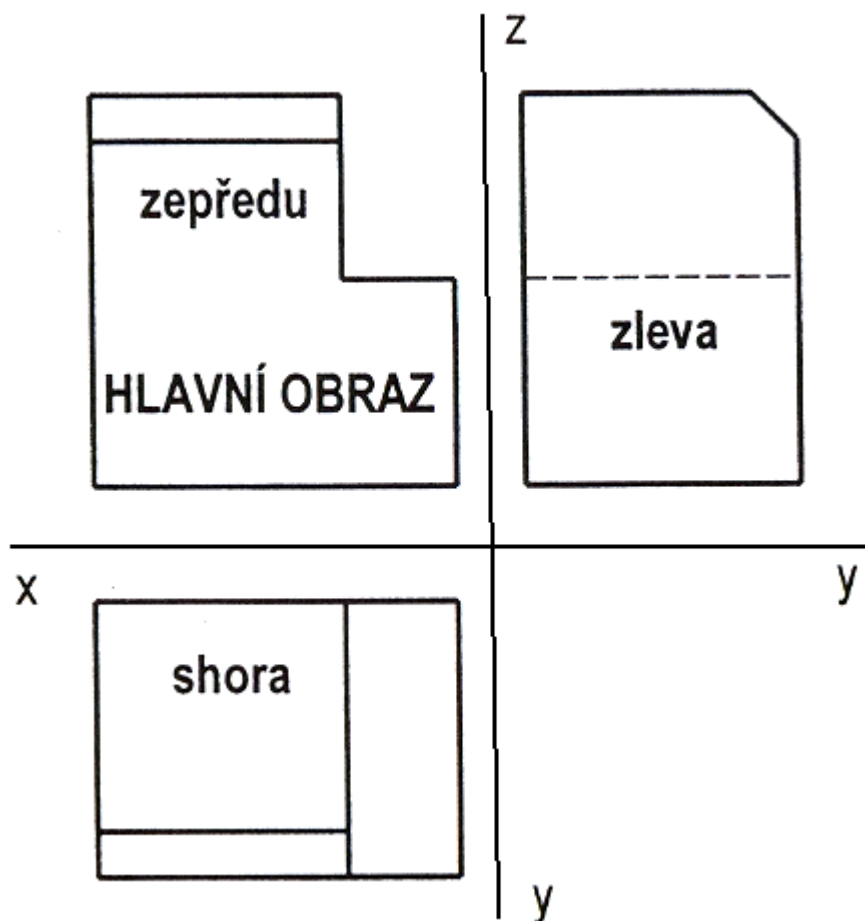

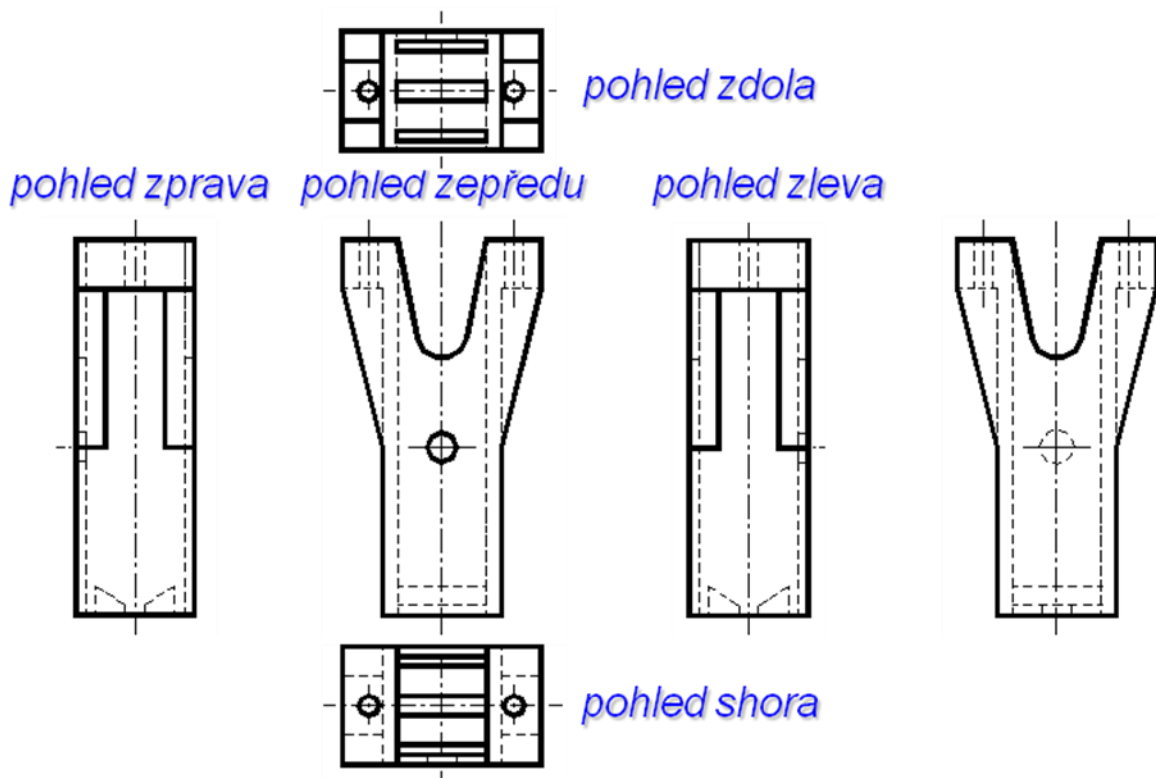
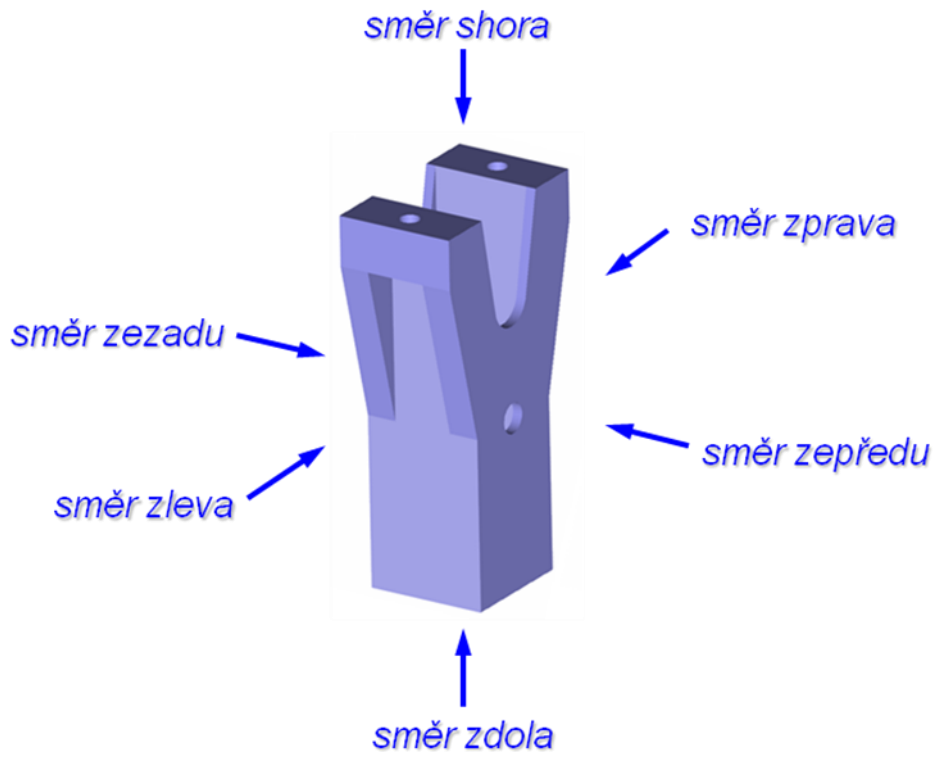











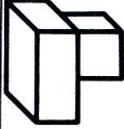

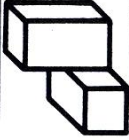

### Doplňte nákresy těles

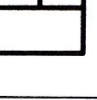
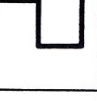
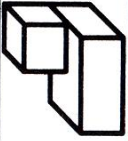
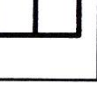
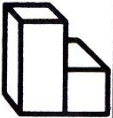
$2\pi$ $\rightarrow$ $1\pi$ $\downarrow$								
								
								
								
								
								
								
								
								

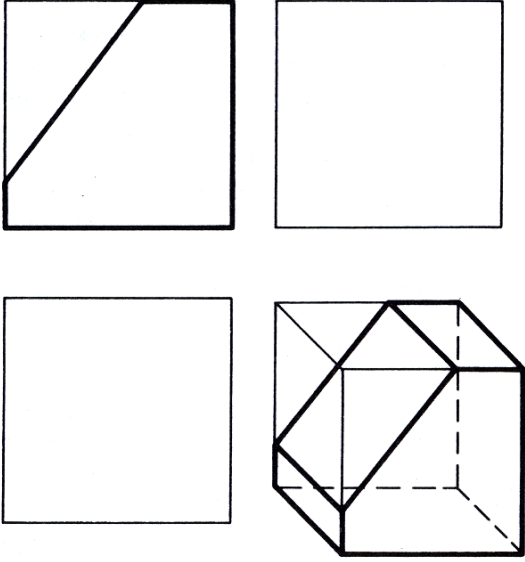
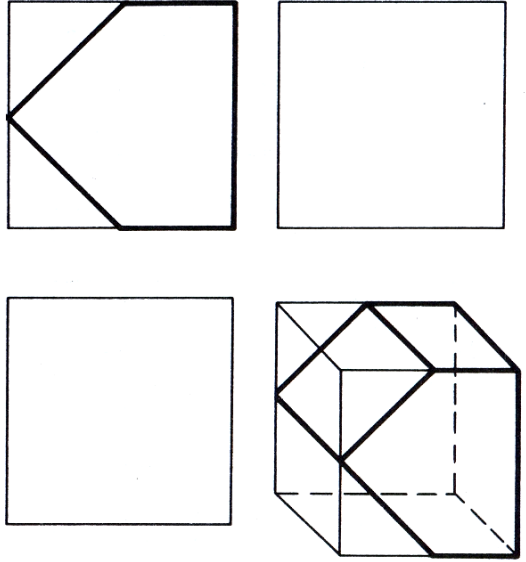
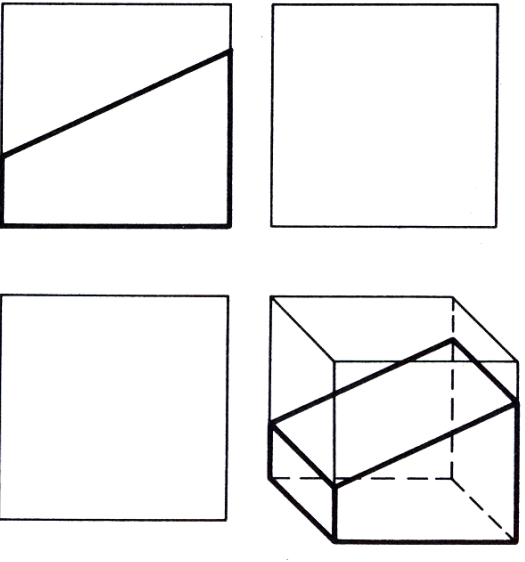
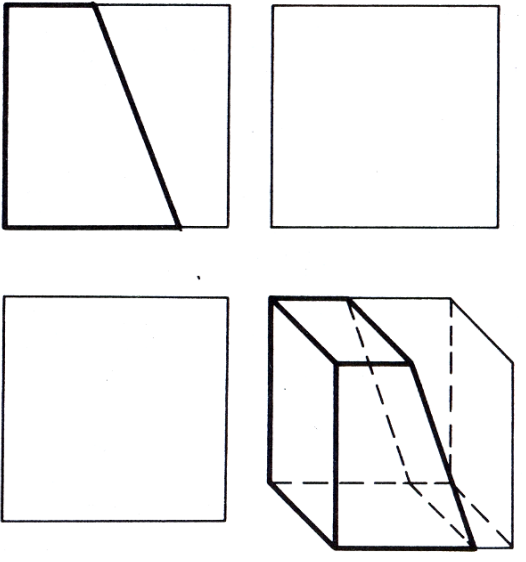

DOPLŇTE CHYBĚJÍCÍ PRŮMĚTY

<p>1</p> 	<p>2</p> 
<p>3</p> 	<p>4</p> 

NAKRESLETE NÁRYS, PŮDORYS A BOKORYS

1

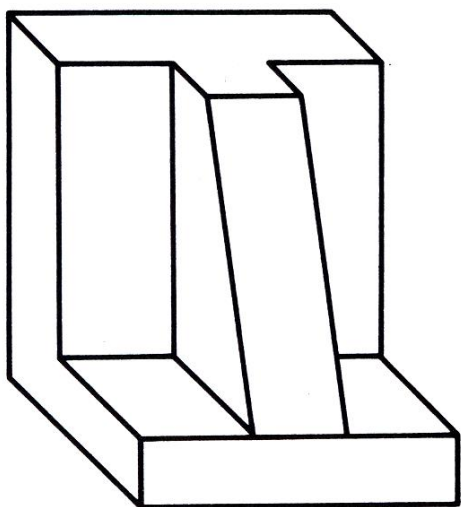

2

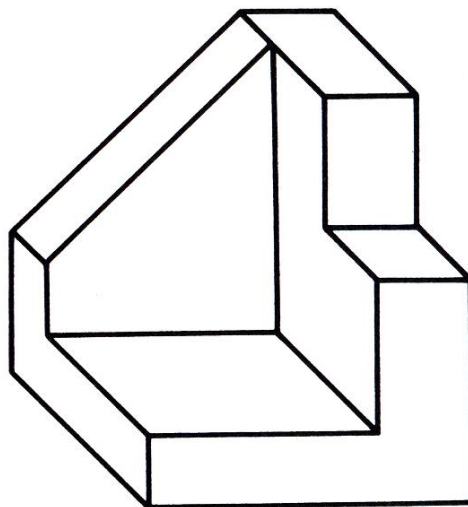

3

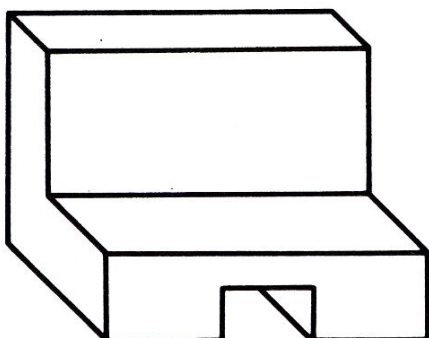

4

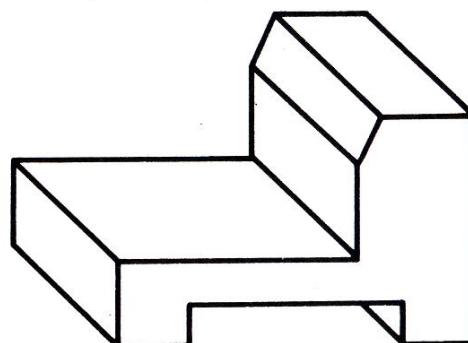

5

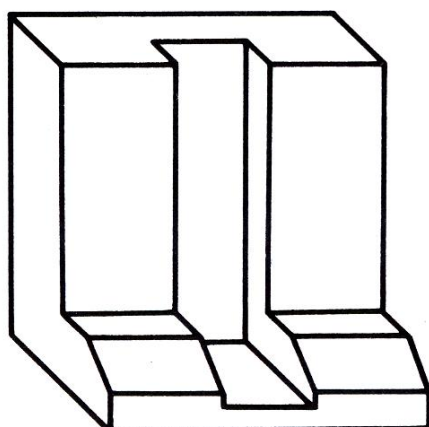

6

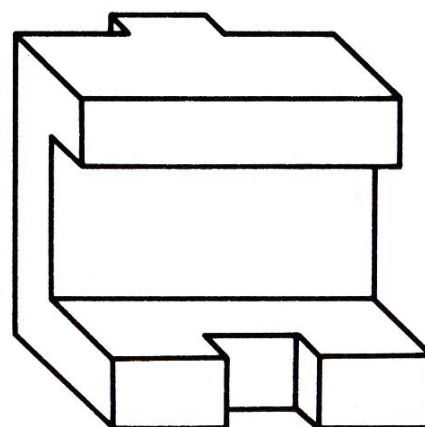

## VYUŽITÍ POMOCNÉ PRŮMĚTNY – VE SMĚRU PROMÍTÁNÍ

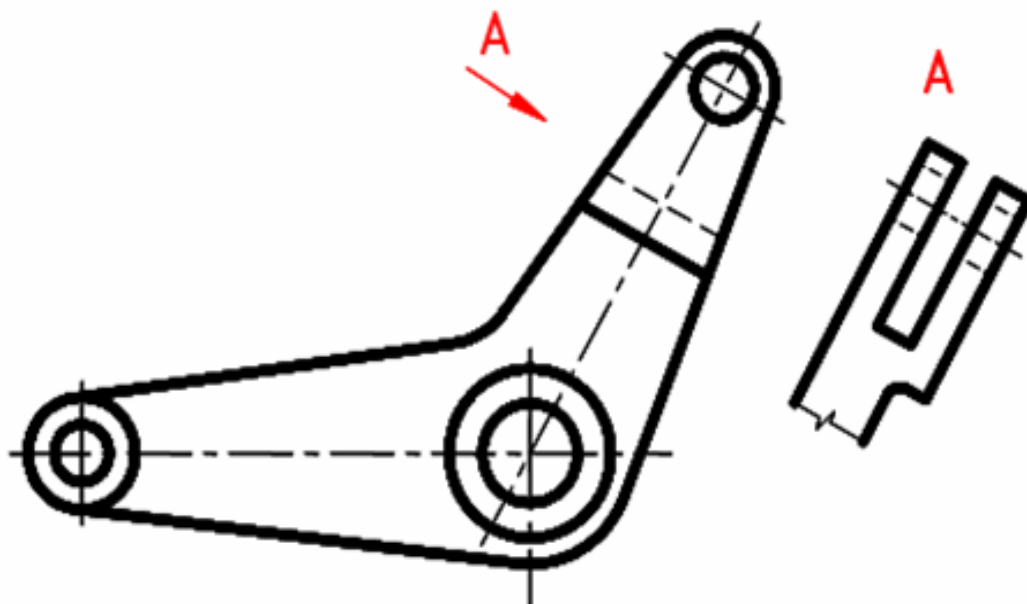
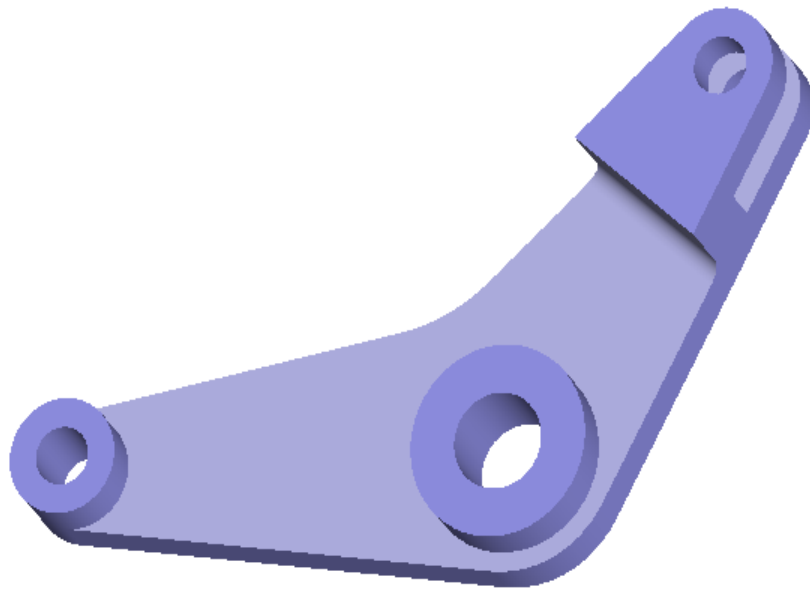



## VYUŽITÍ POMOCNÉ PRŮMĚTNY – MIMO SMĚR PROMÍTÁNÍ

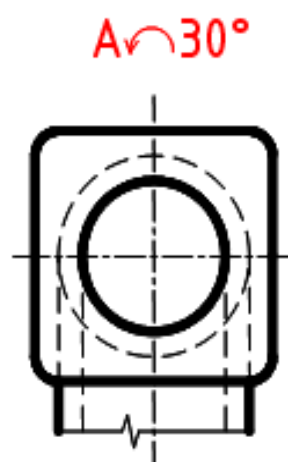
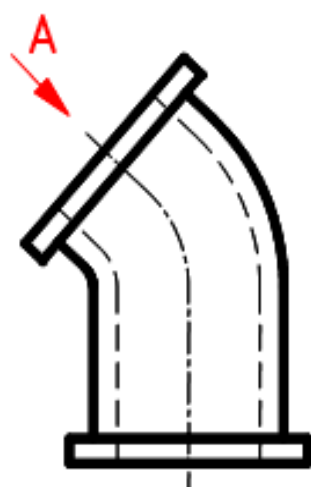
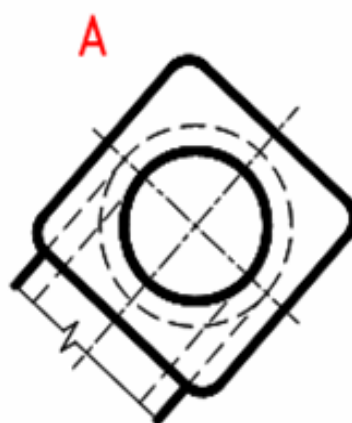
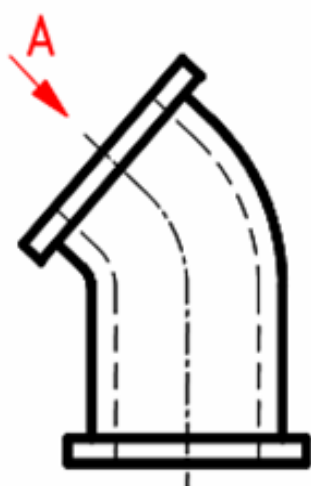
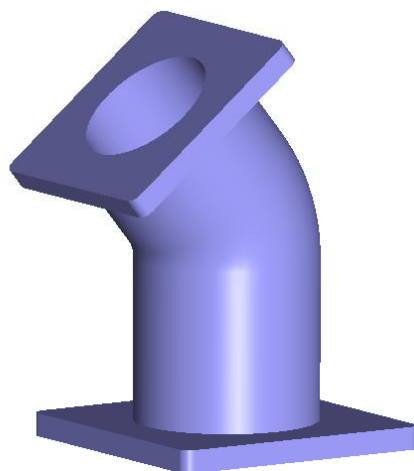

## **CVIČENÍ 3**

# **AXONOMETRICKÉ PROMÍTÁNÍ**

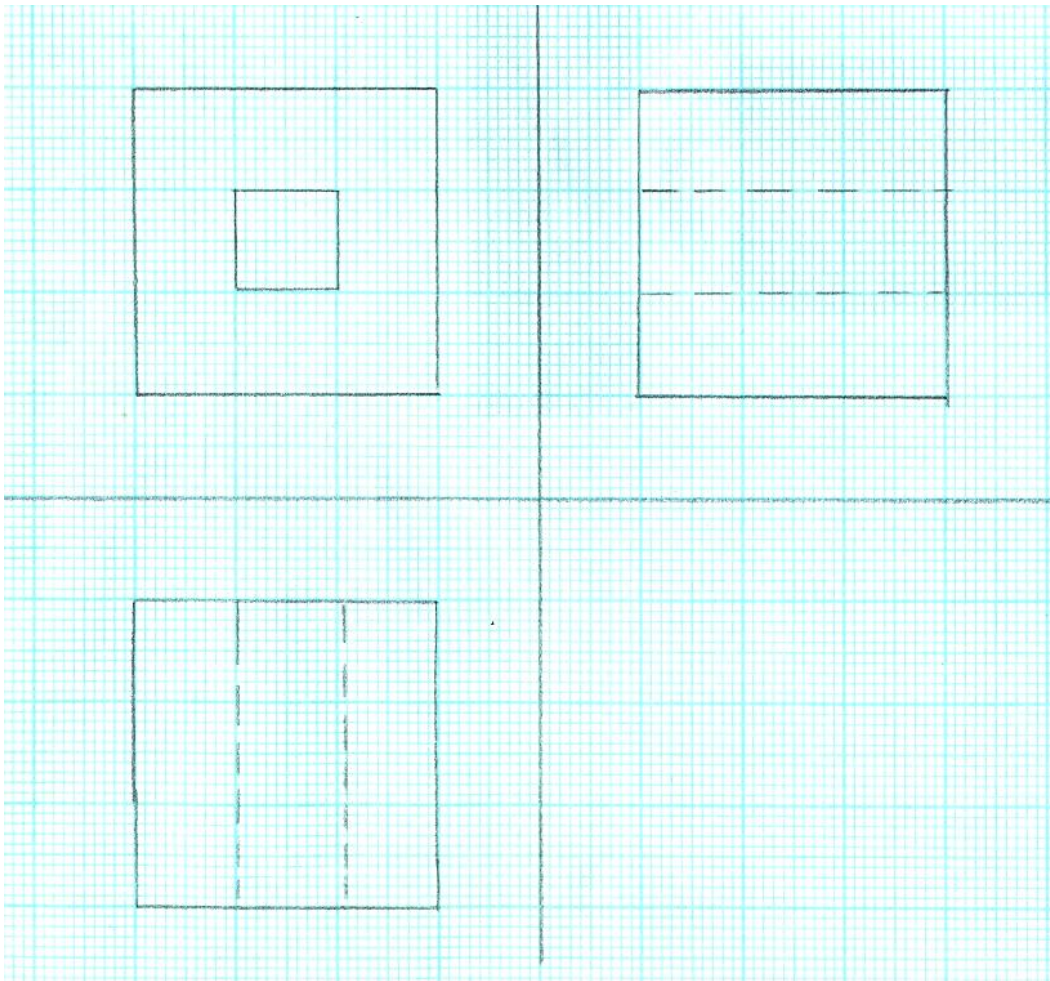
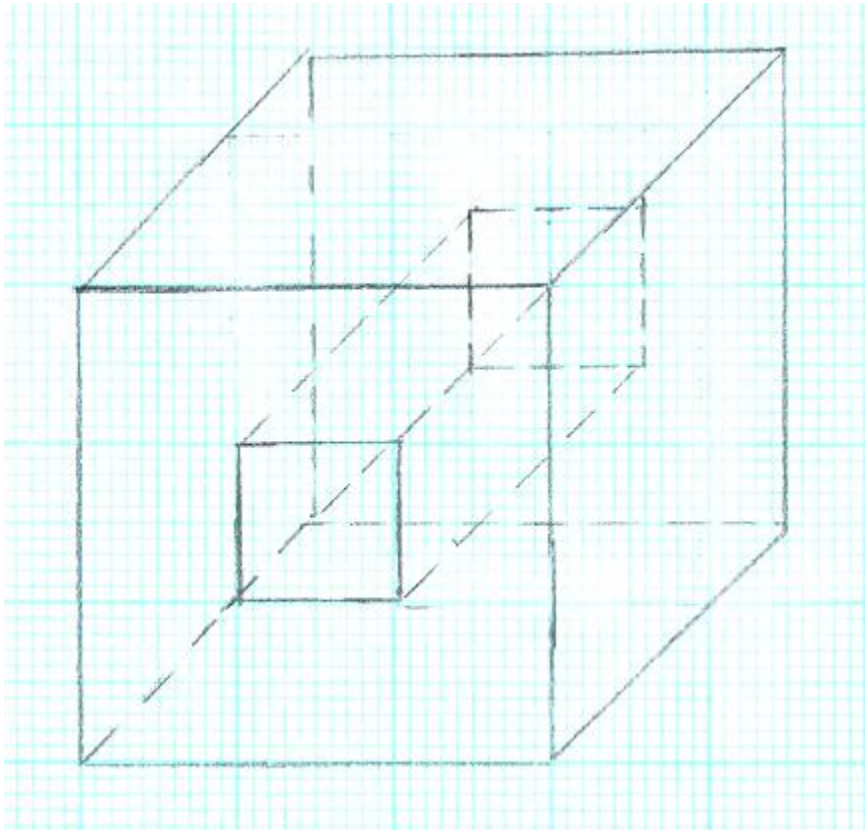

**IZOMETRIE**

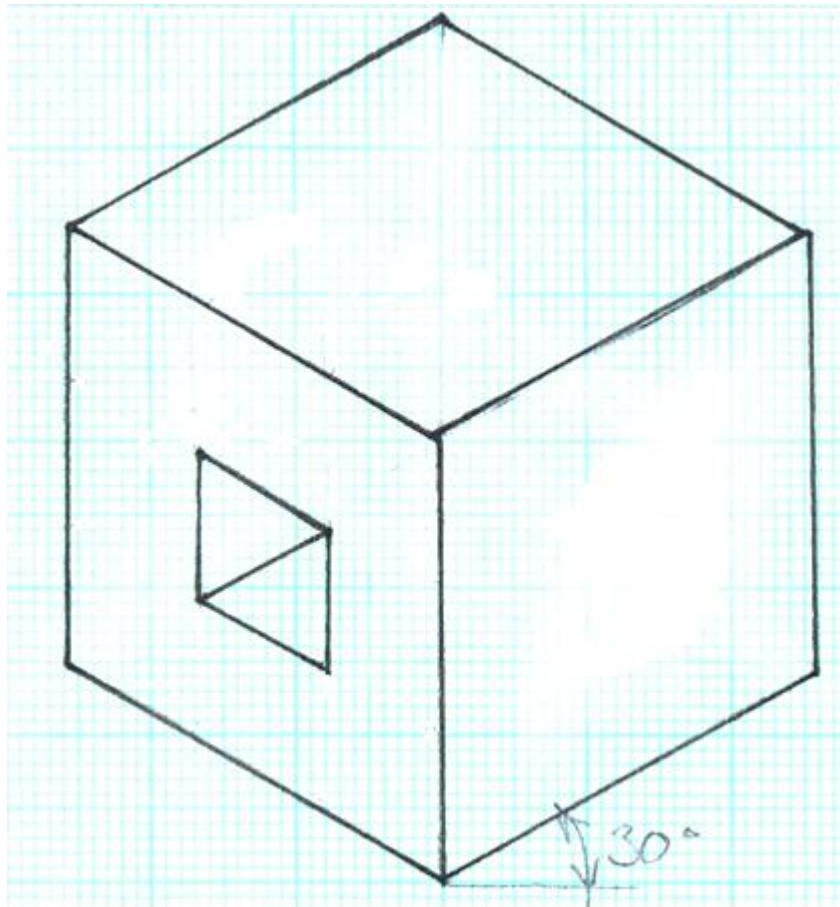

**AXONOMETRIE**

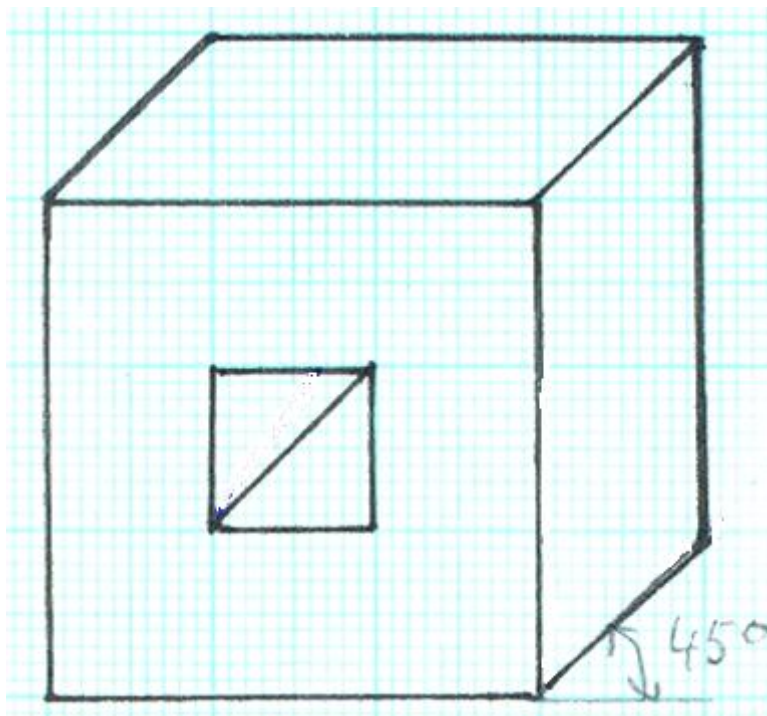



## NAKTESLETE V AXONOMETRII A IZOMETRII

V NÁRYSU 2, 3 – IZOMETRIE

V NÁRYSU 1, 4 - AXONOMETRIE

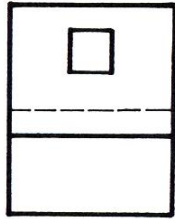
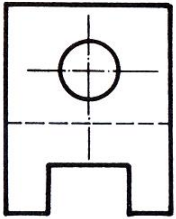
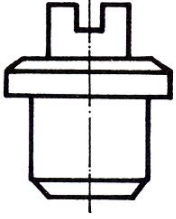
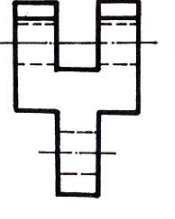
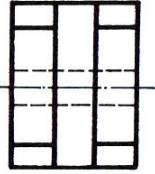
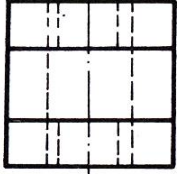
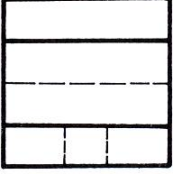
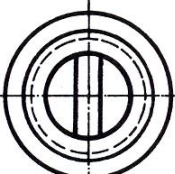
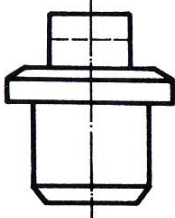
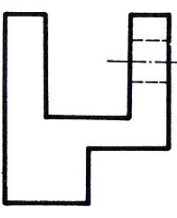
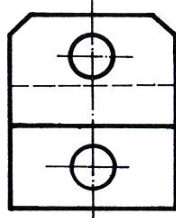
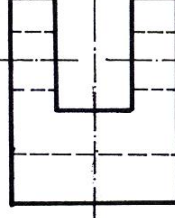
NÁRYS	1 	2 	3 	4 
PŮDORYS	1 	2 	3 	4 
BOKORYS	1 	2 	3 	4 



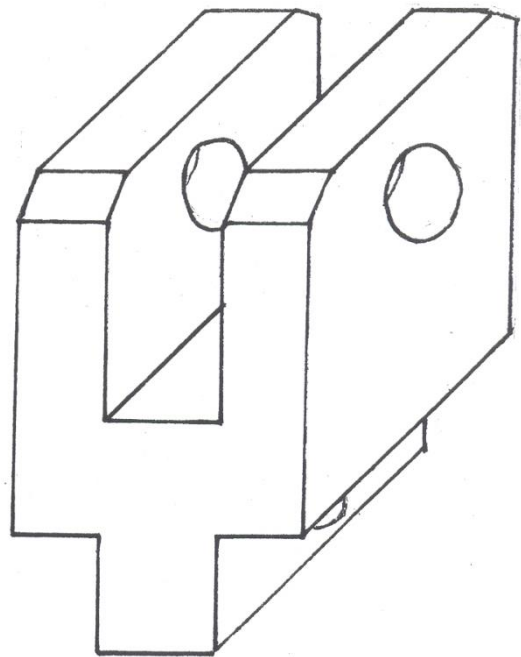
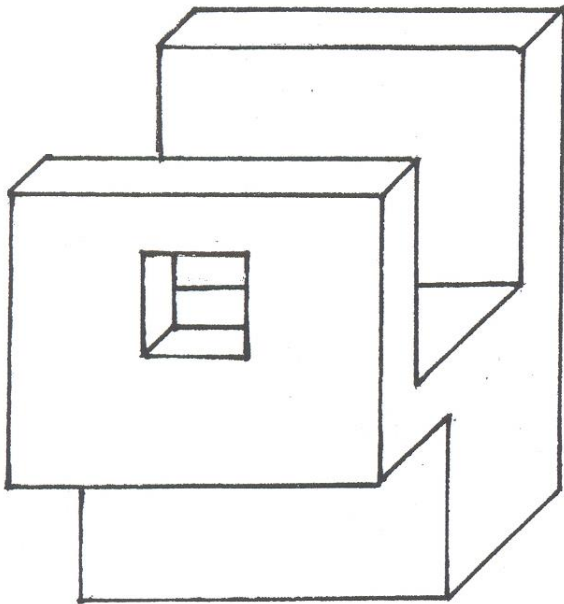
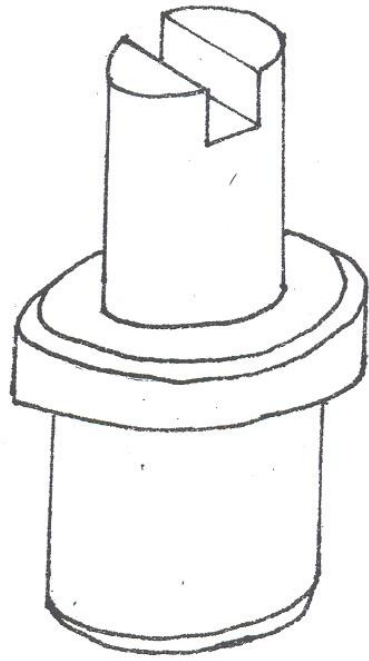
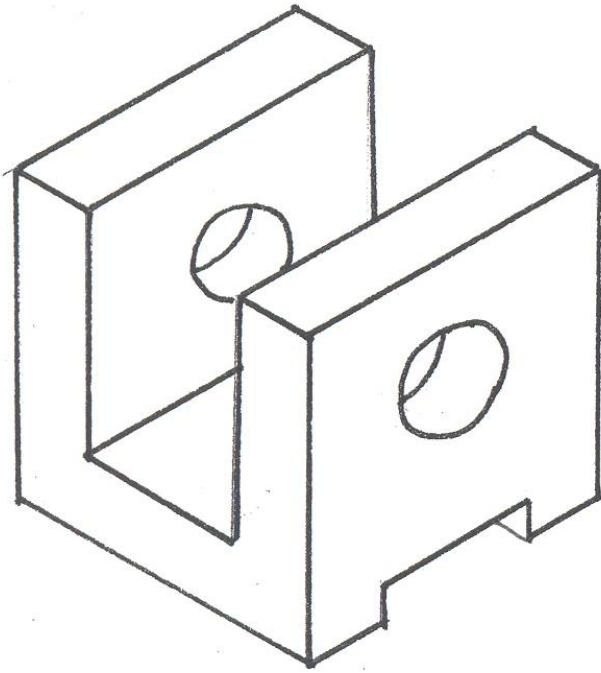

# PROCVIČTE SI AXONOMETRICKÉ ZOBRAZOVÁNÍ

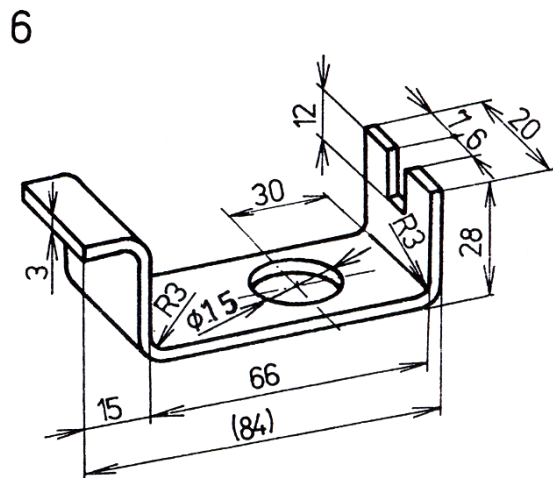
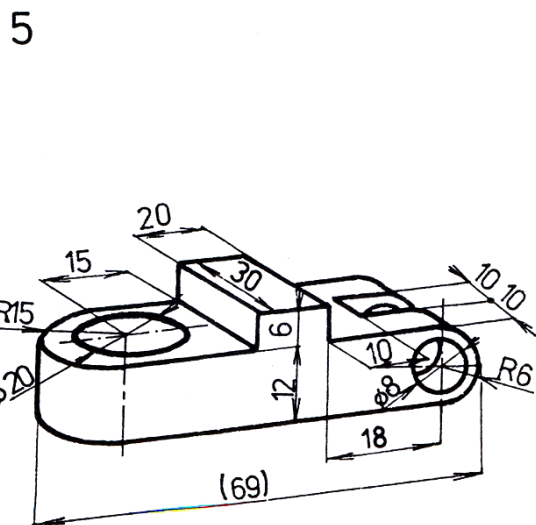
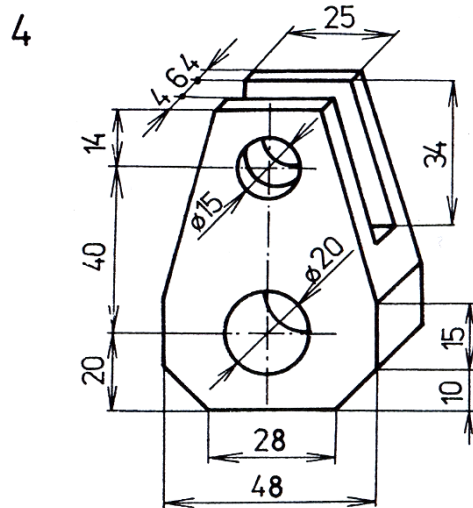
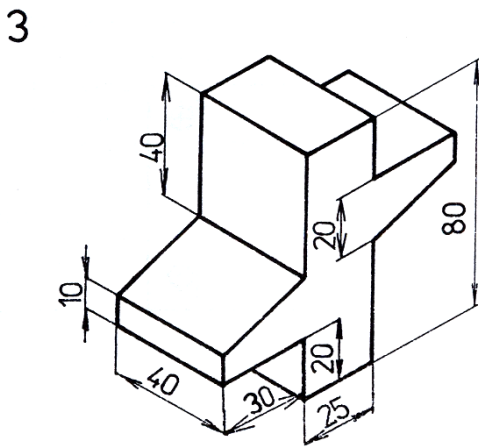
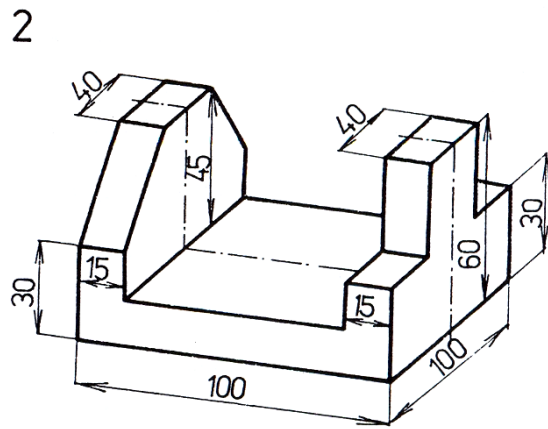
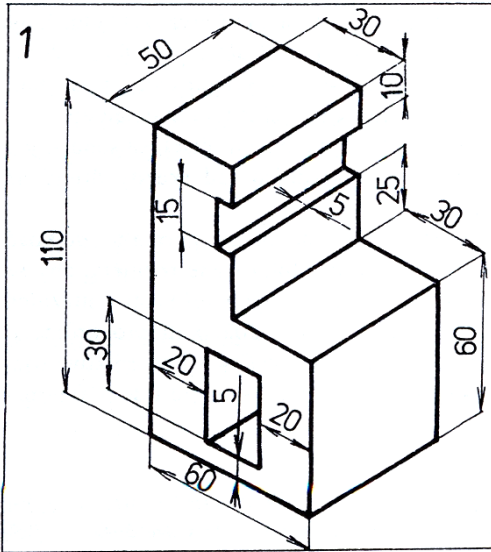

# **CVIČENÍ 4**

## **ŘEZY**

ŘEZY

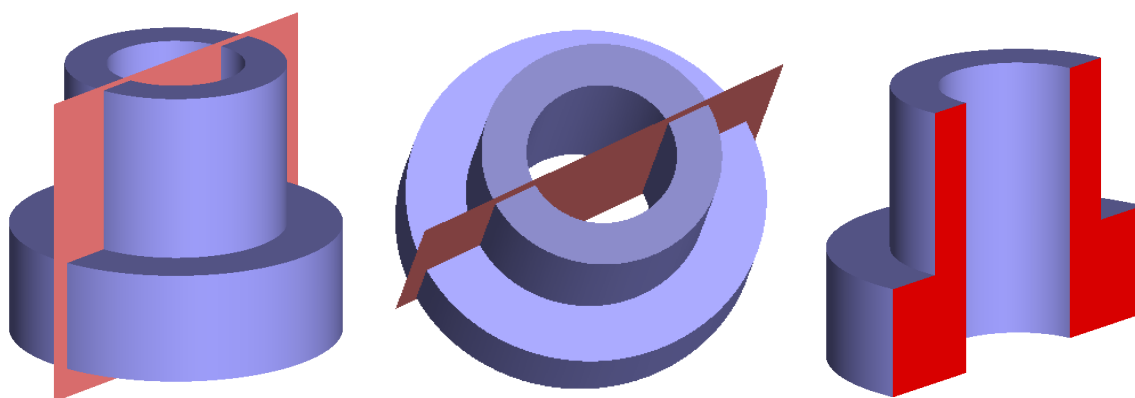

A-A

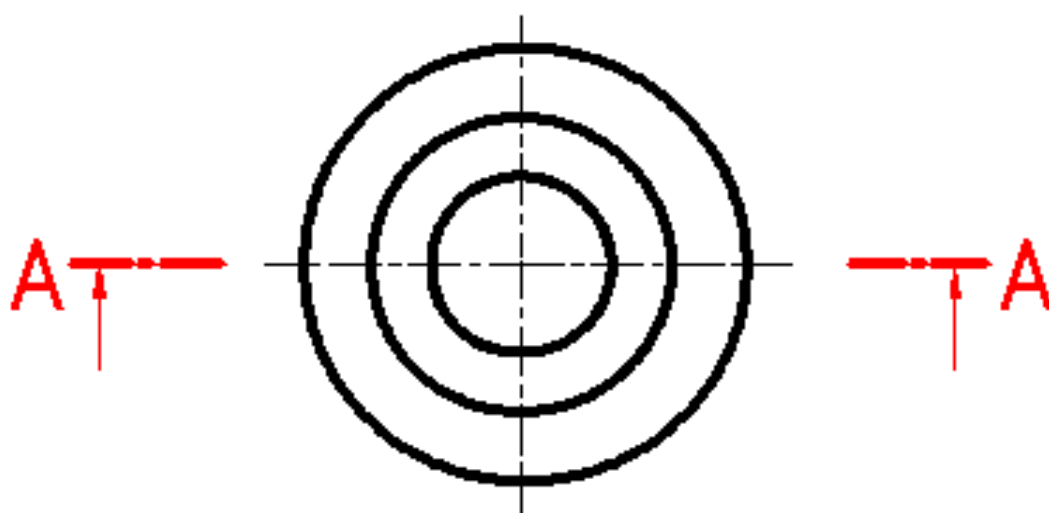
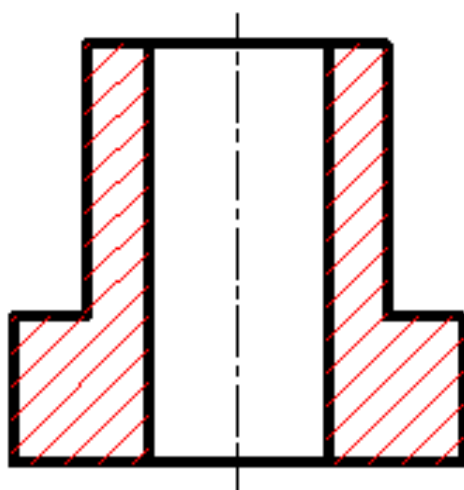



*Univerzální vzor, obsahuje-li výkres pouze jednu součást, kovy*

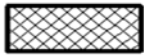

*Plasty*



*Sklo a transparentní materiály*



*Keramika a porcelán*

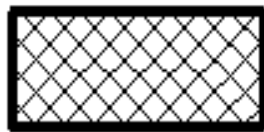
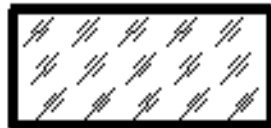



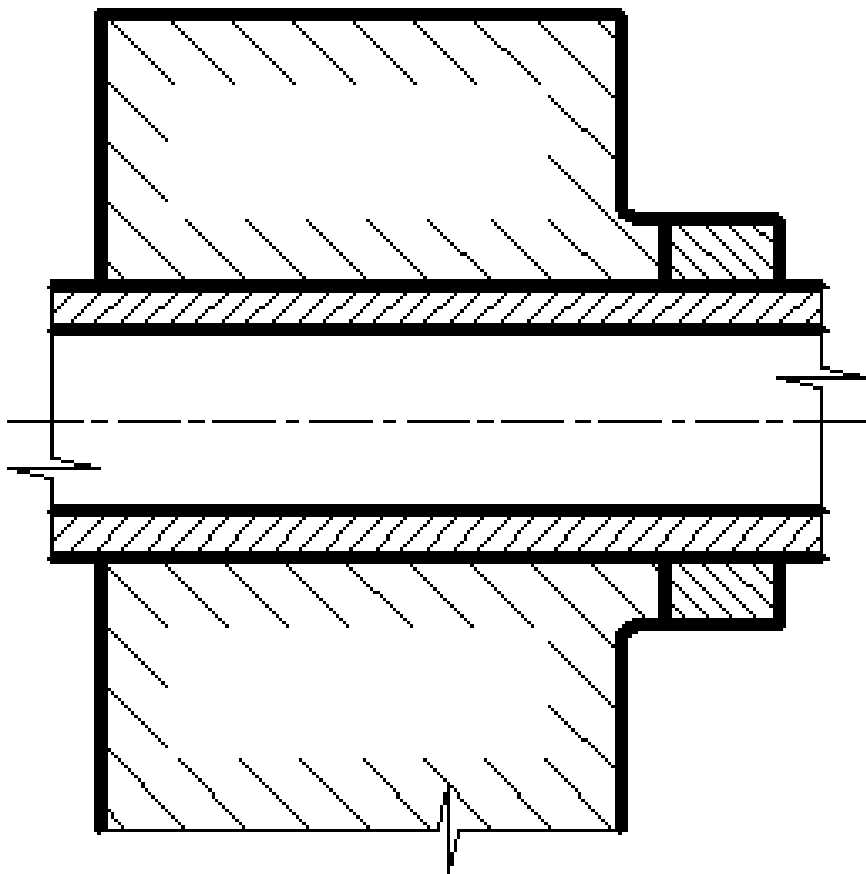
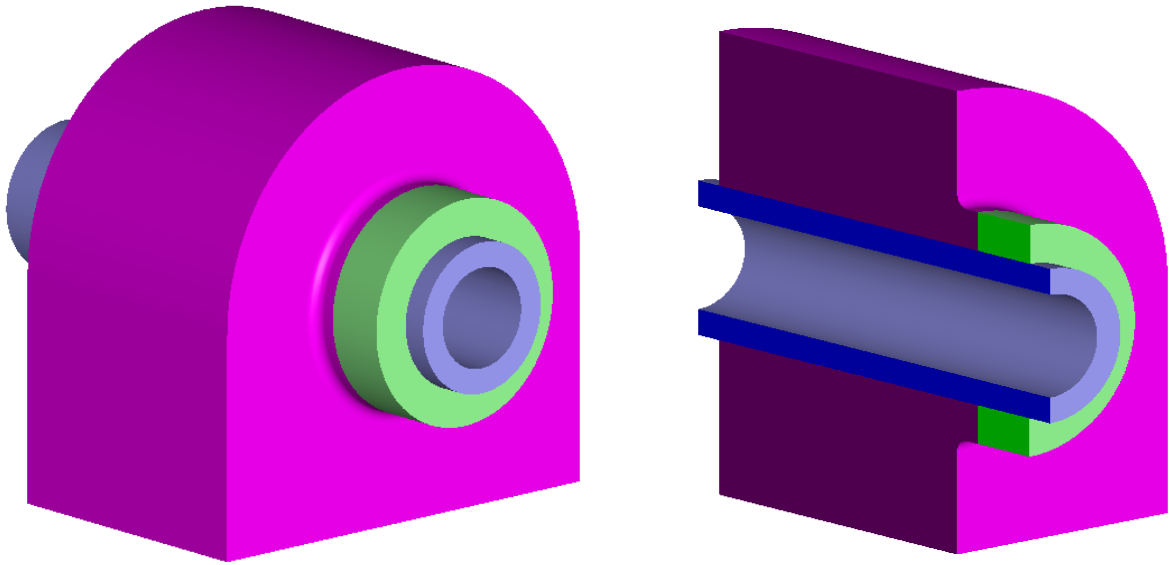

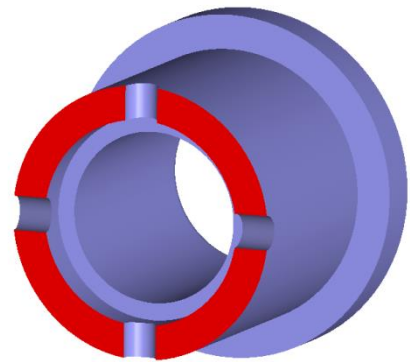
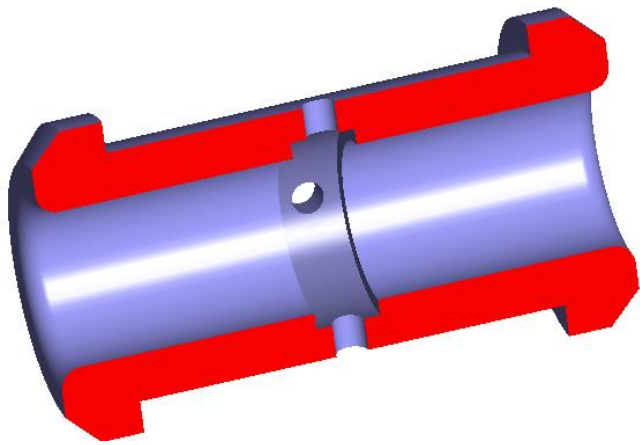
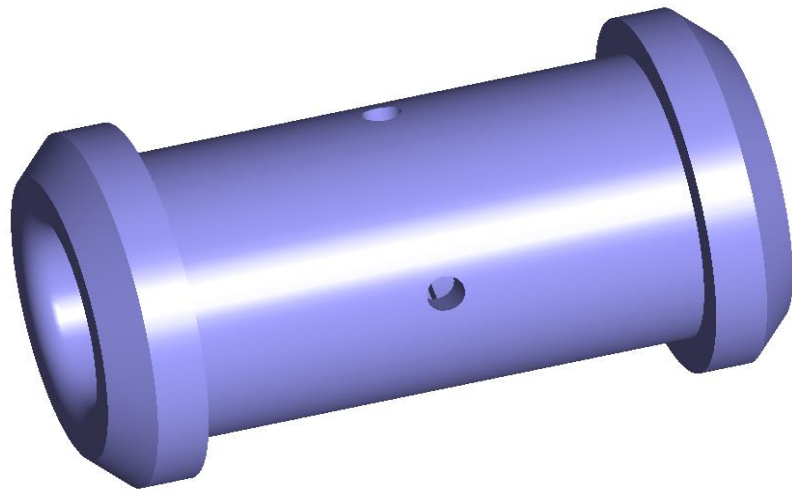

B-B

A



A-A B

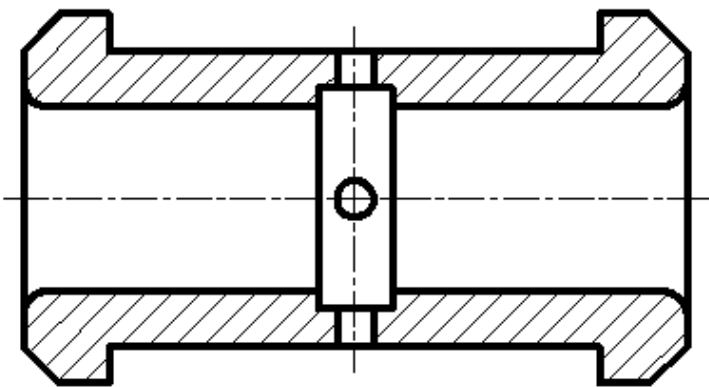

A

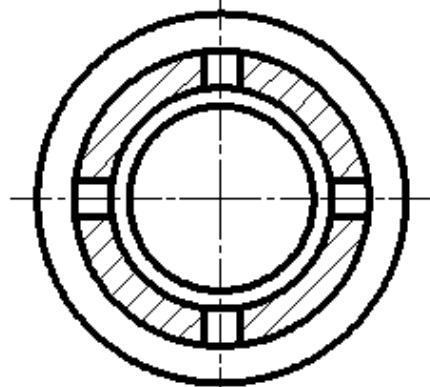

B

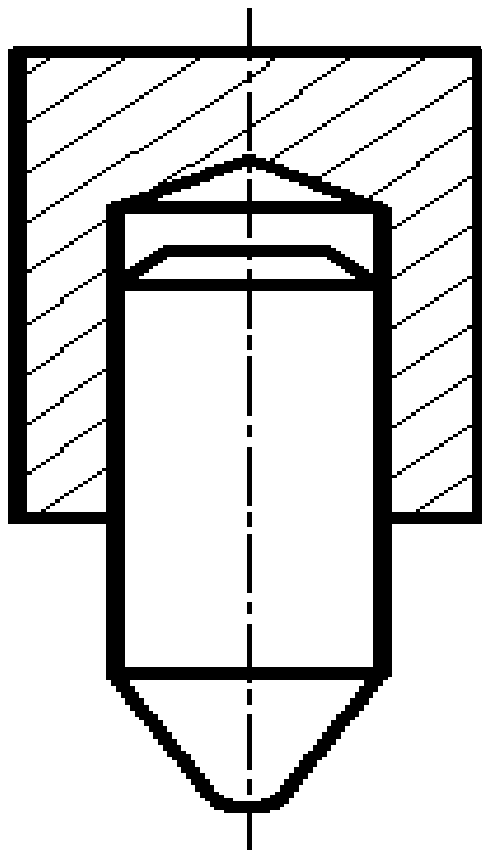
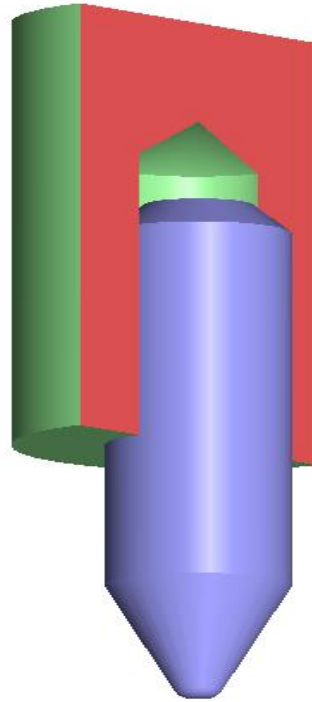
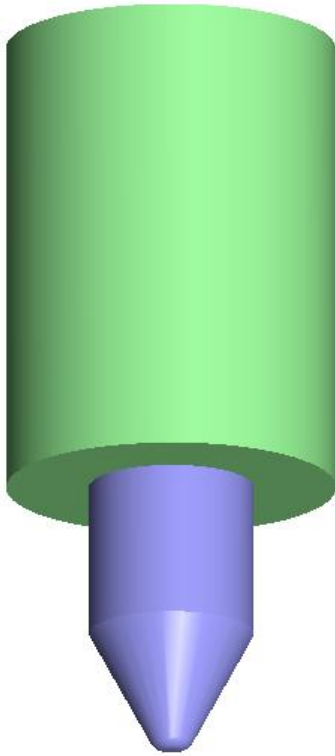

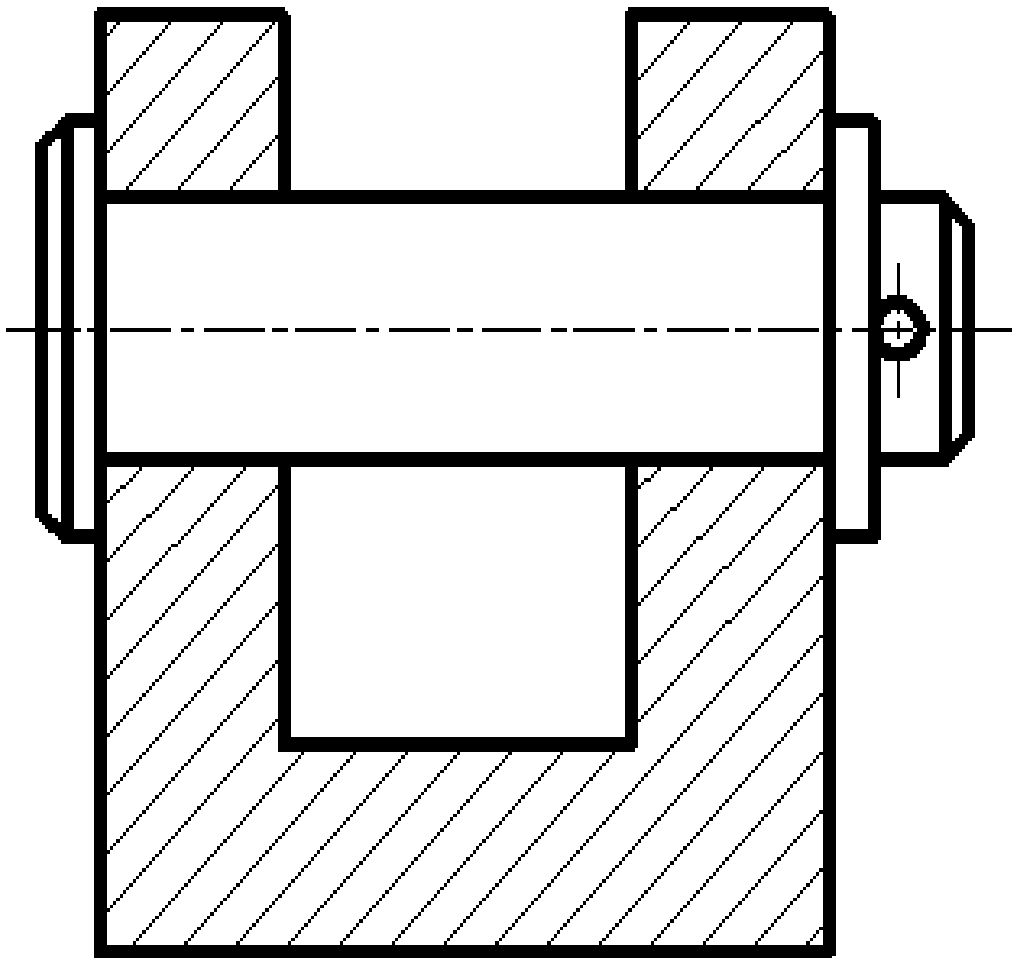
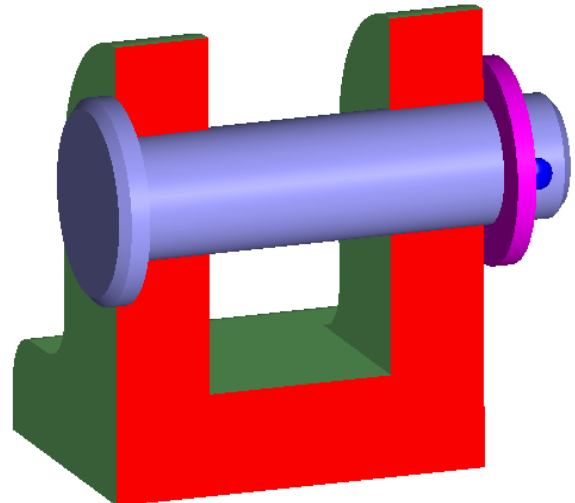
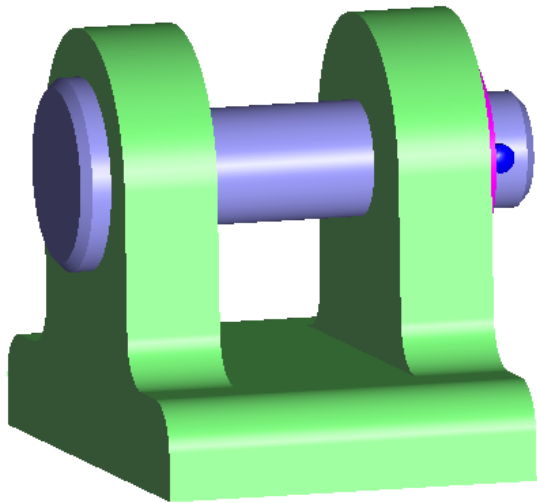

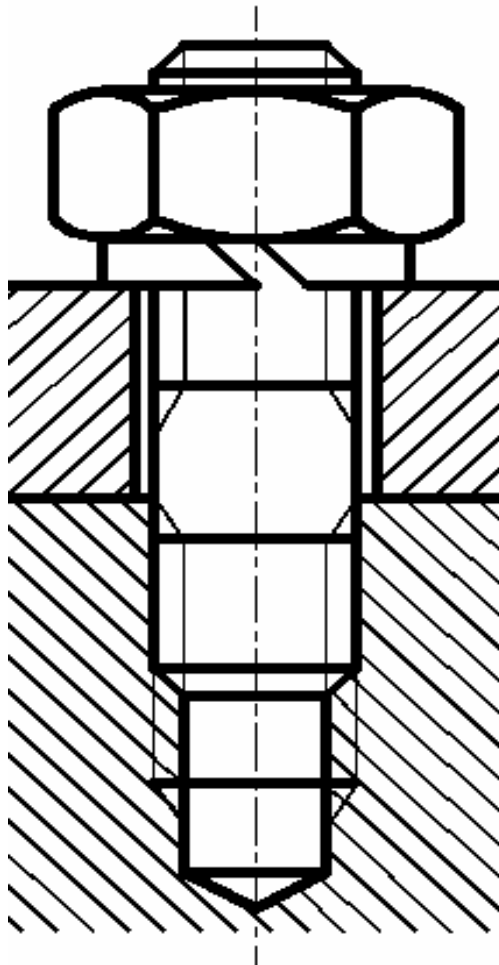
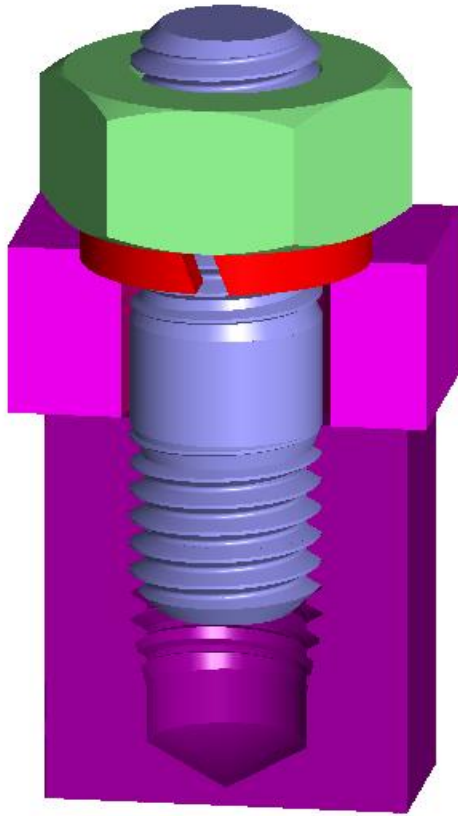



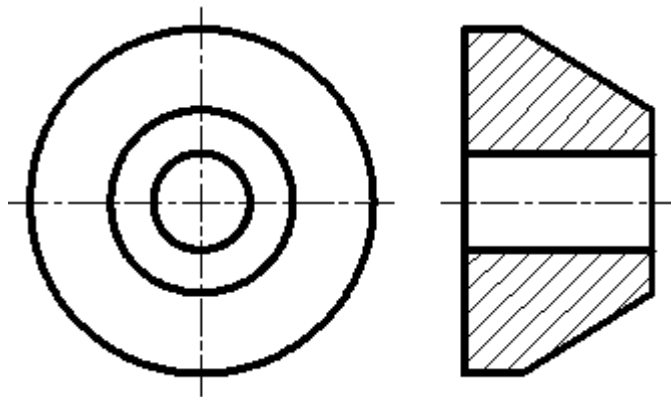
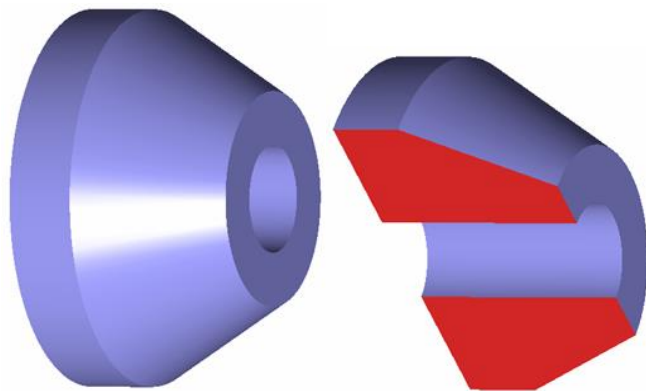
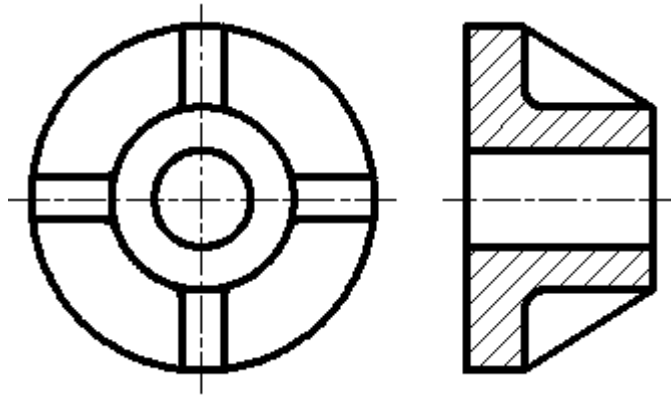
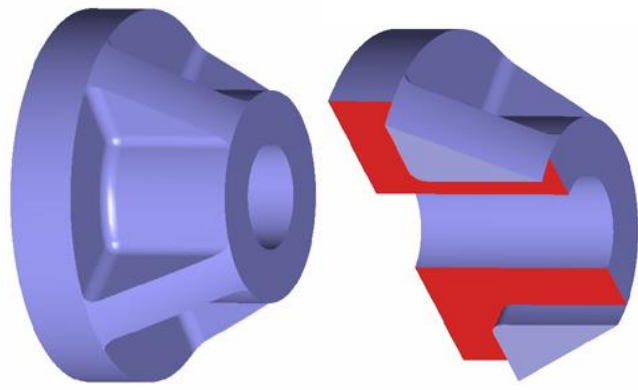

# POLOVIČNÍ ŘEZ

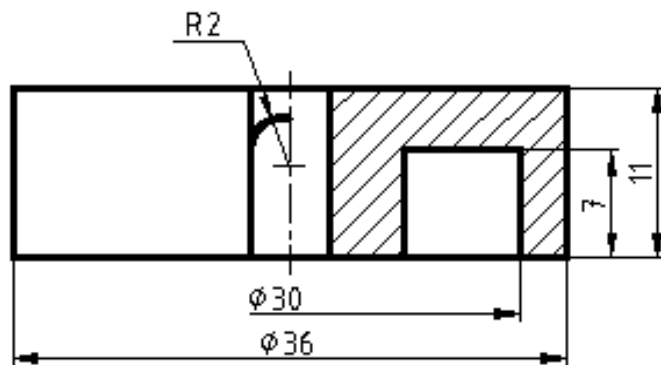
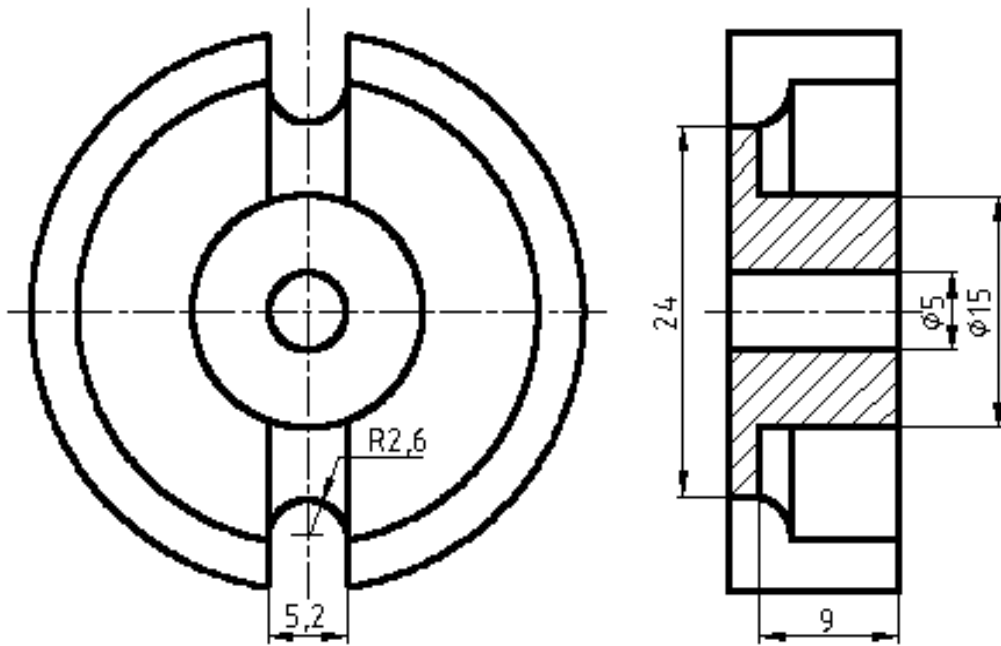
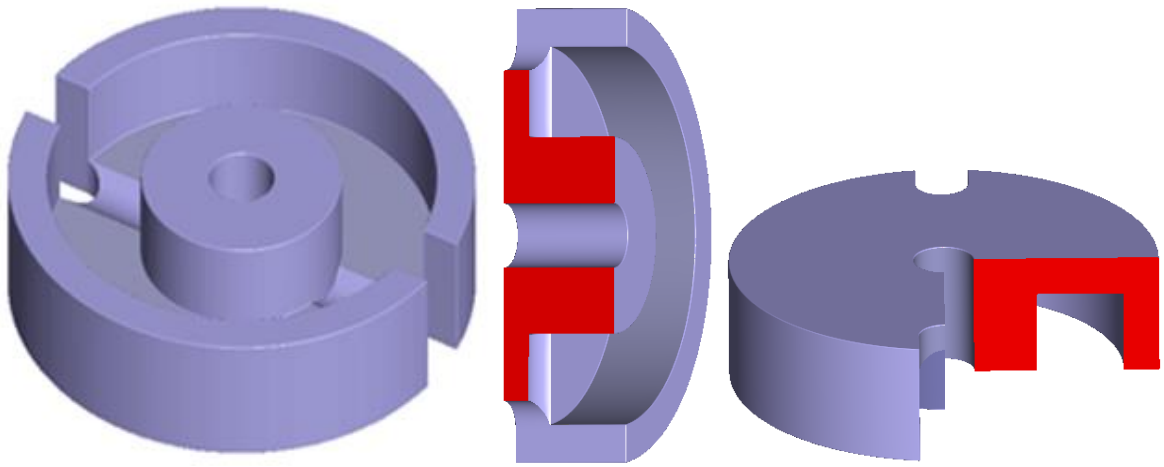

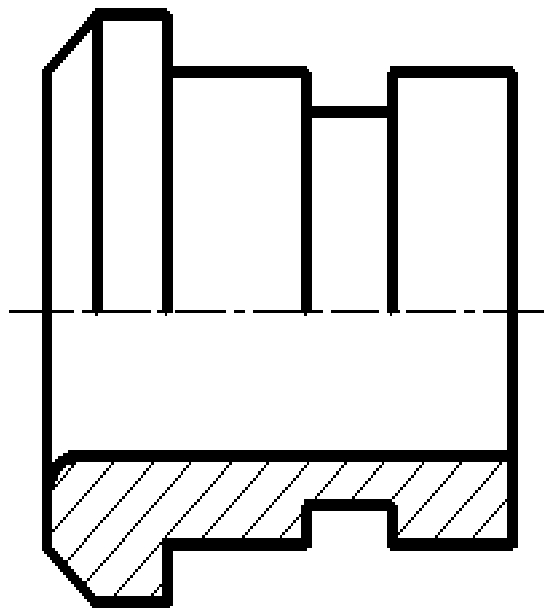
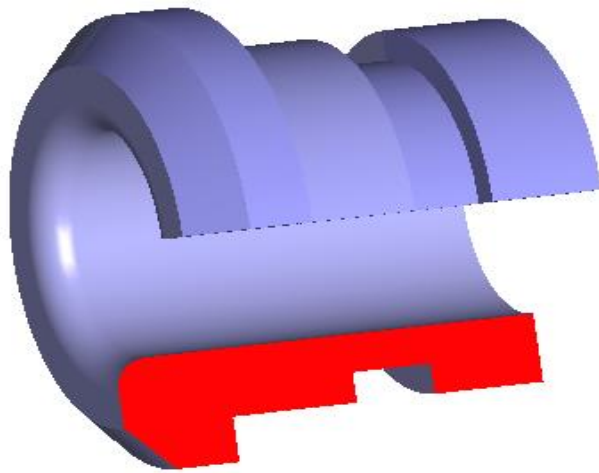
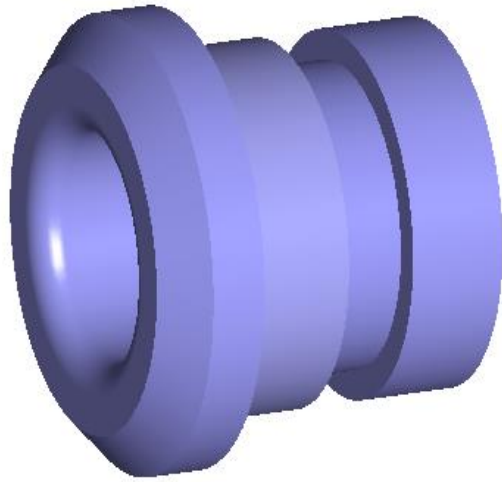

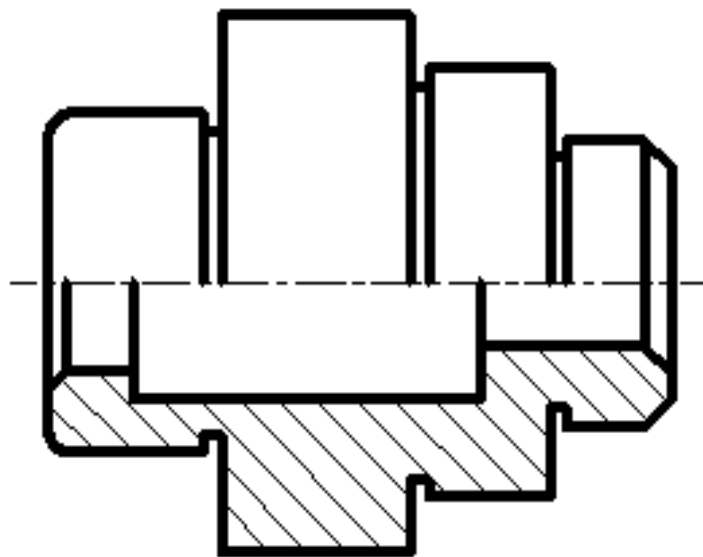
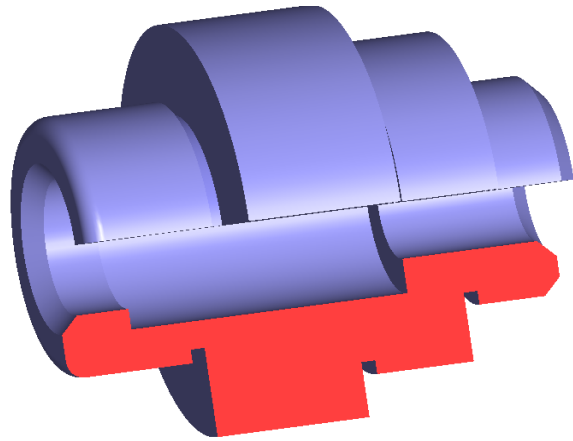
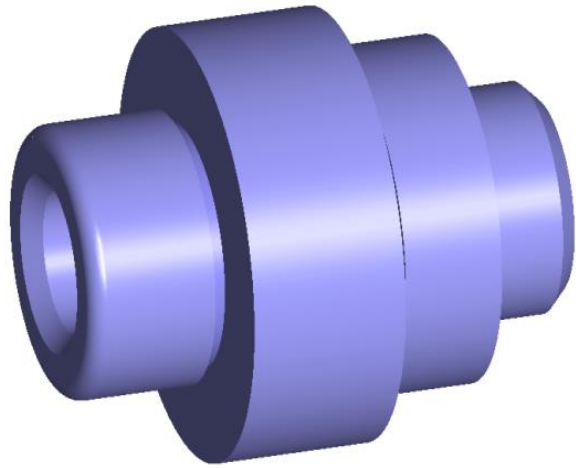

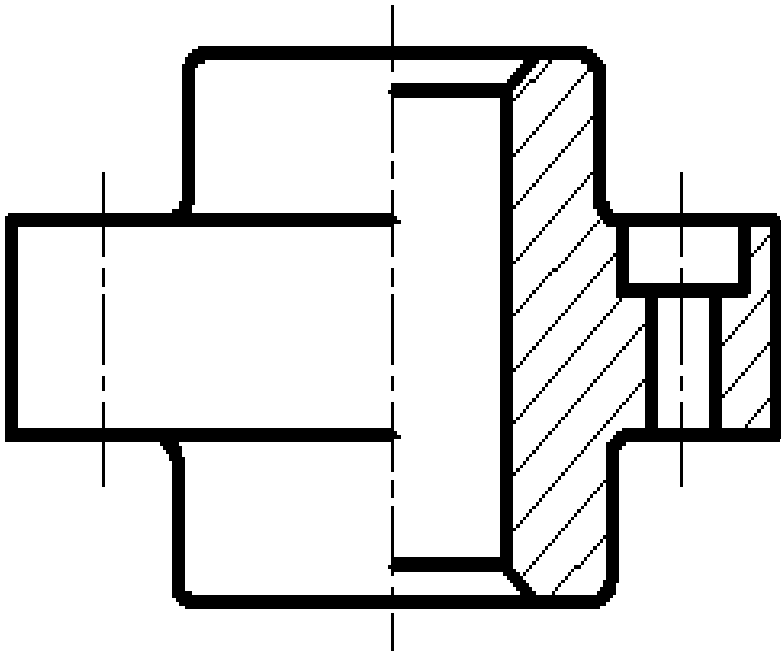
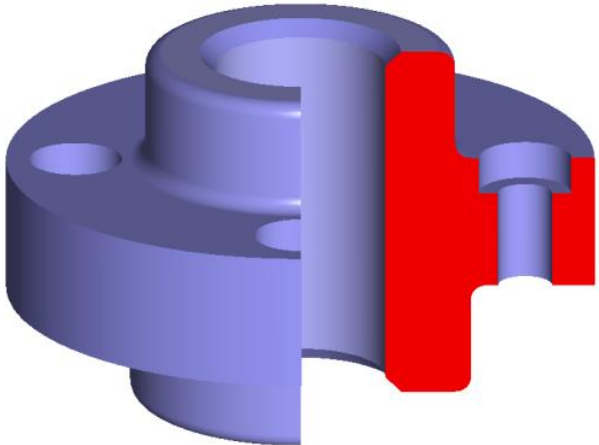
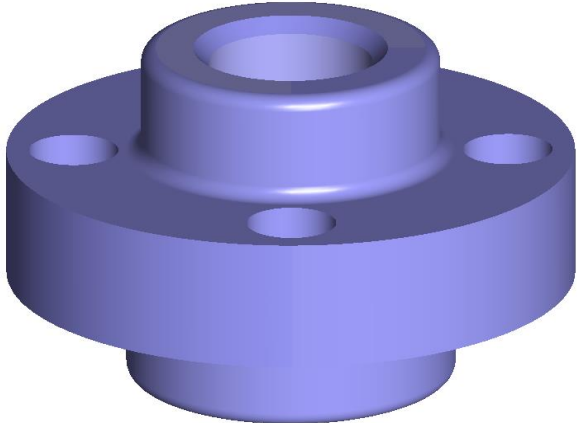



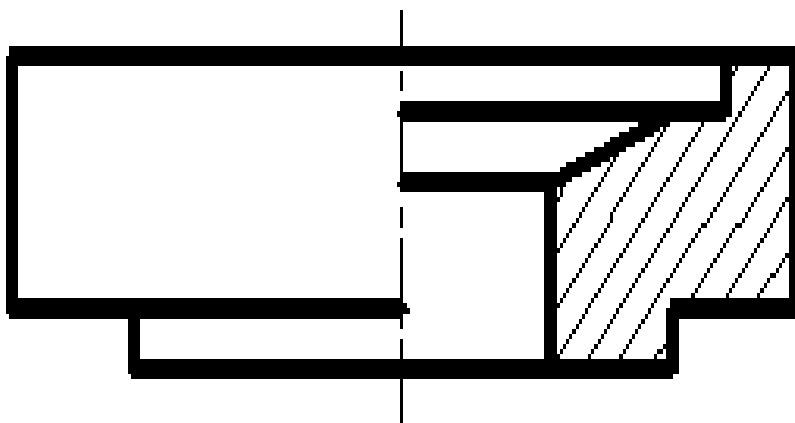
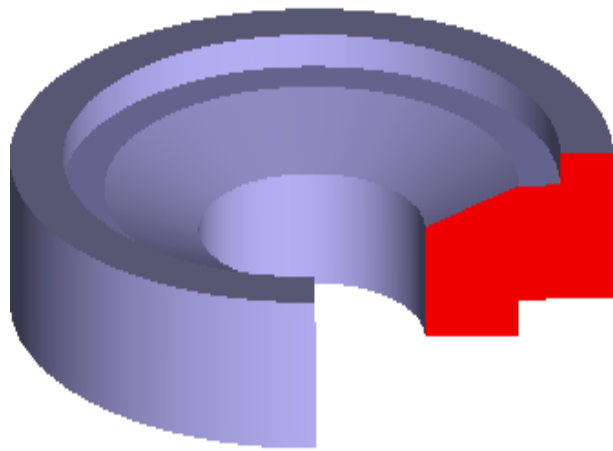
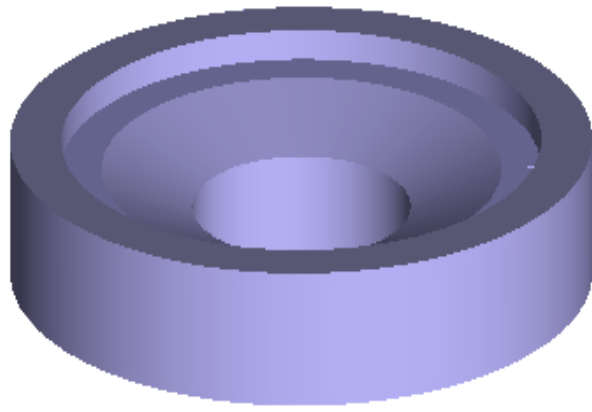

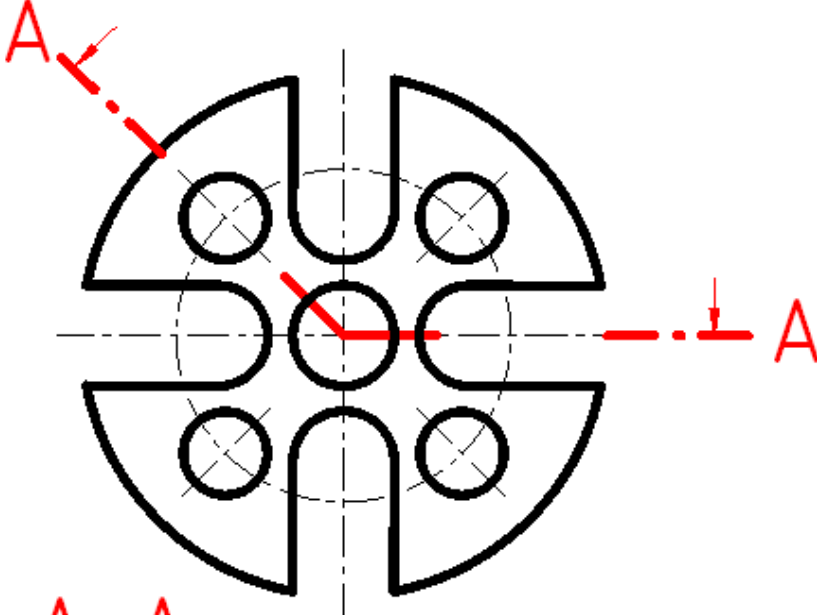
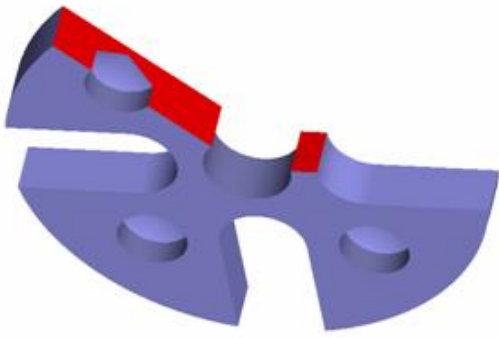
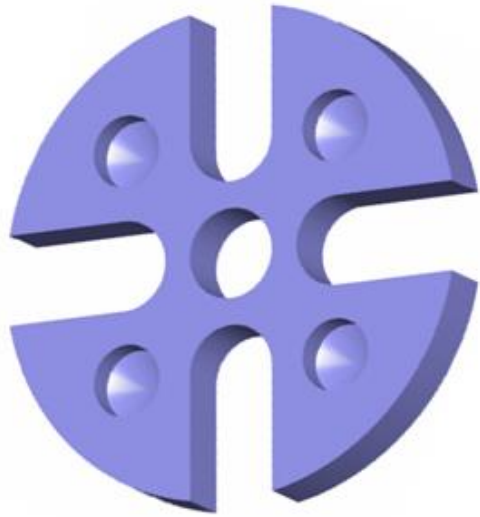

A-A

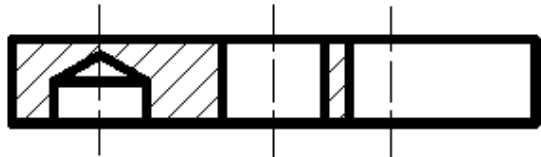

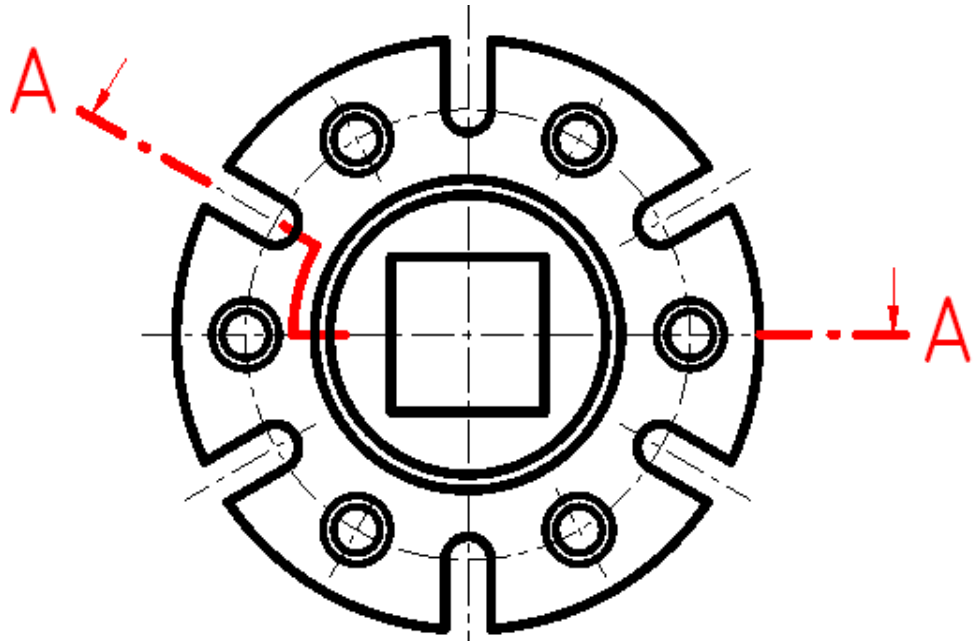
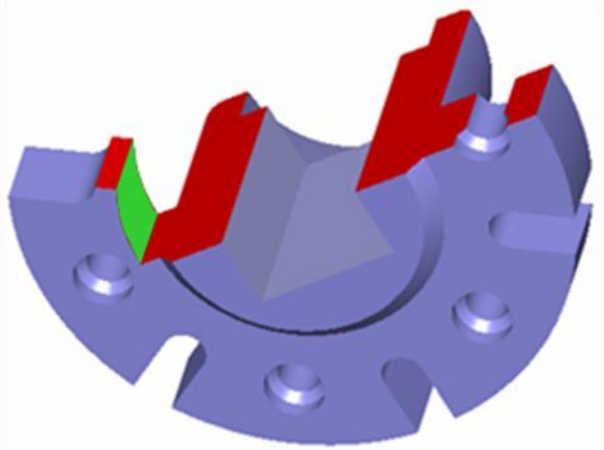
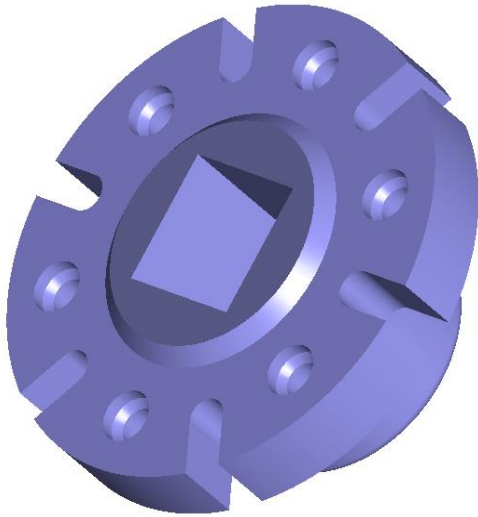

A-A

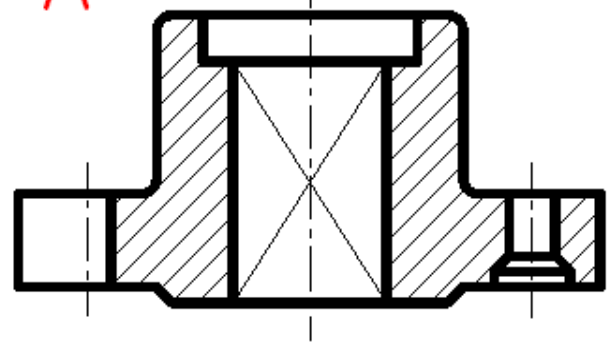

# **CVIČENÍ 5**

## **ŘEZY A PRŮŘEZY**

# MÍSTNÍ ŘEZ

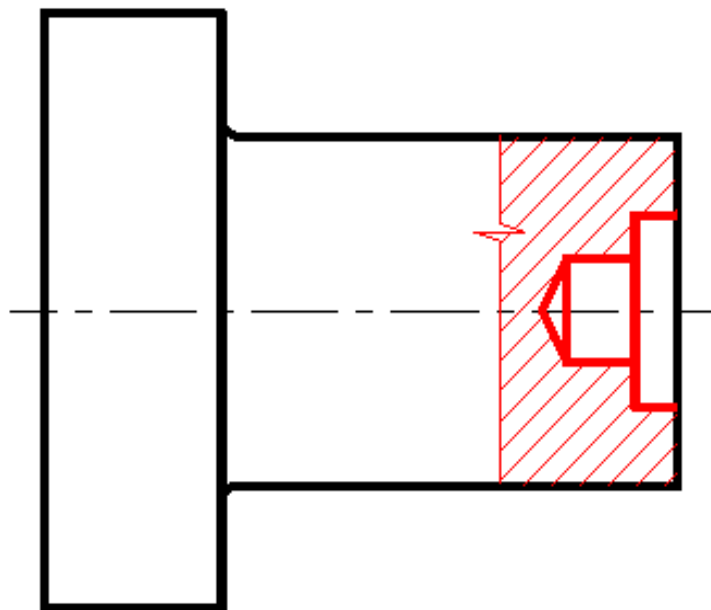
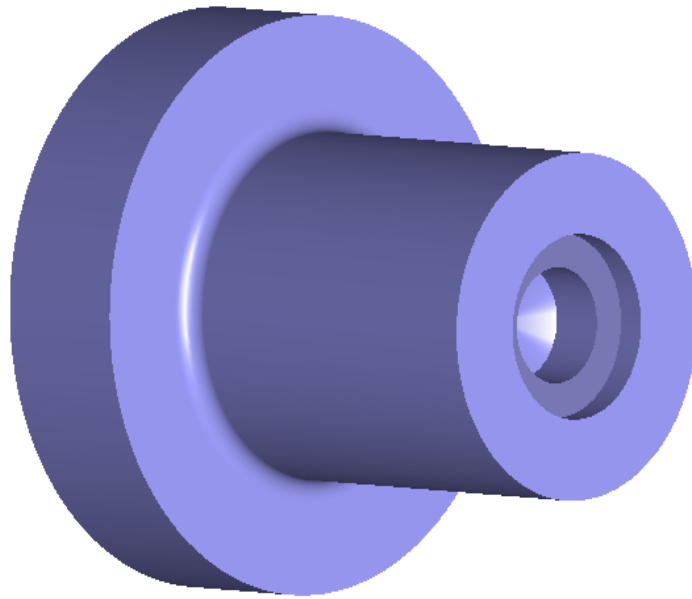

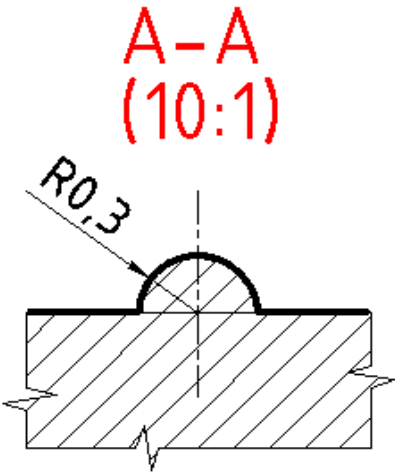
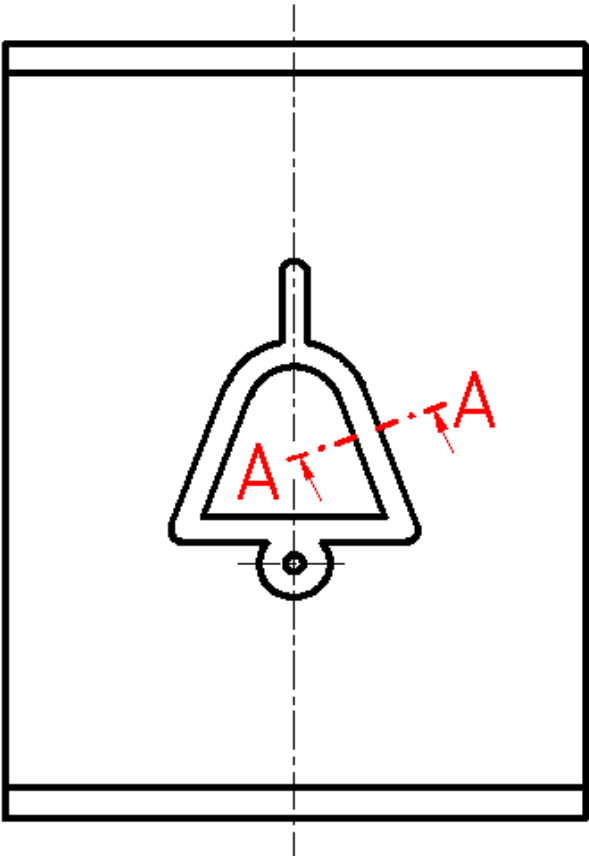
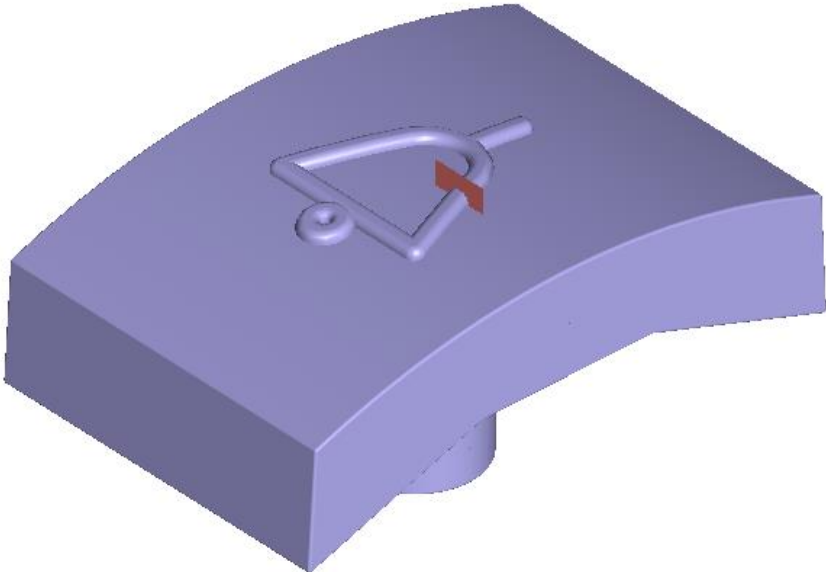

# ROZVINUTÝ ŘEZ

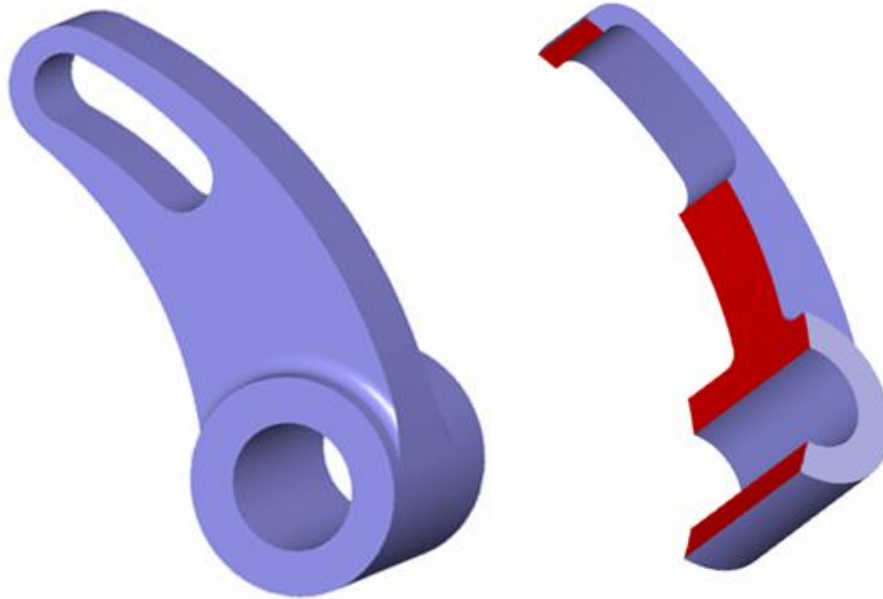

A-A

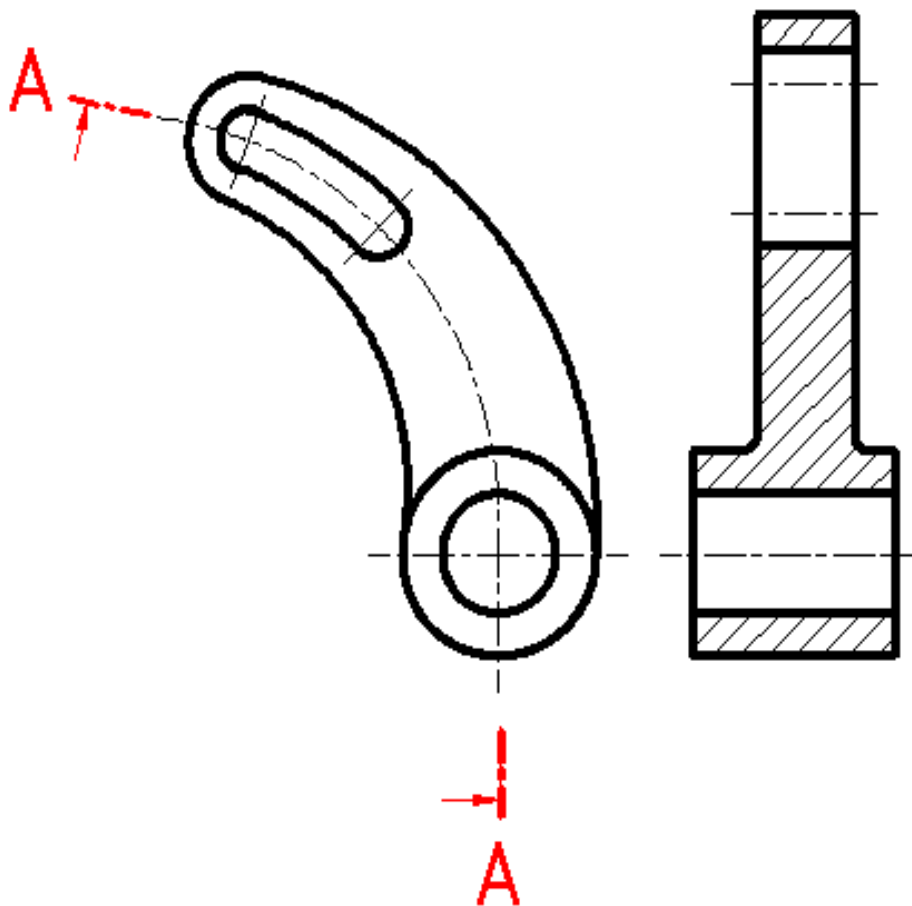



# ŘEZ A PRŮŘEZ

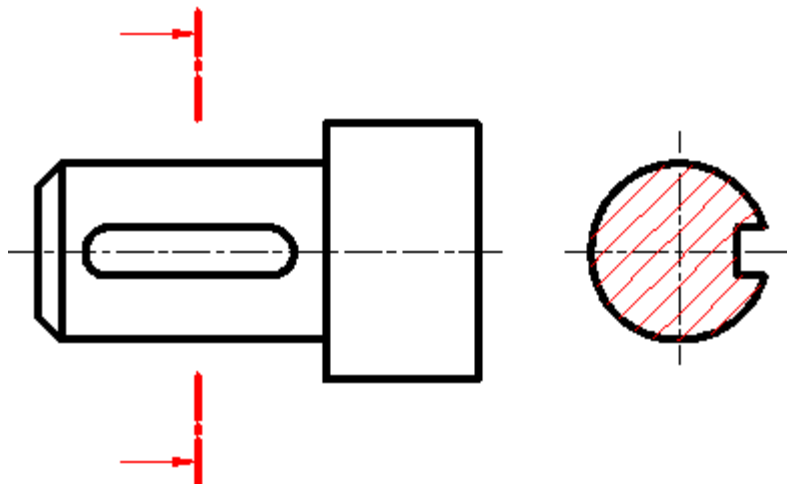
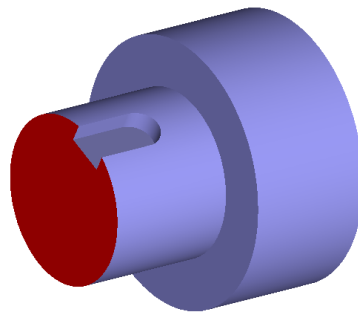
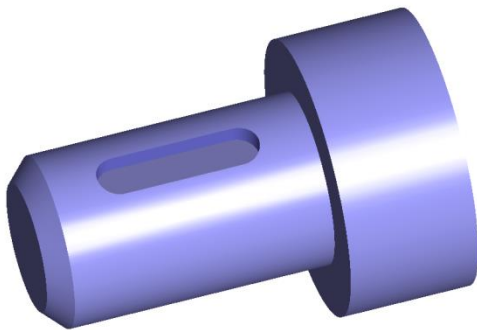
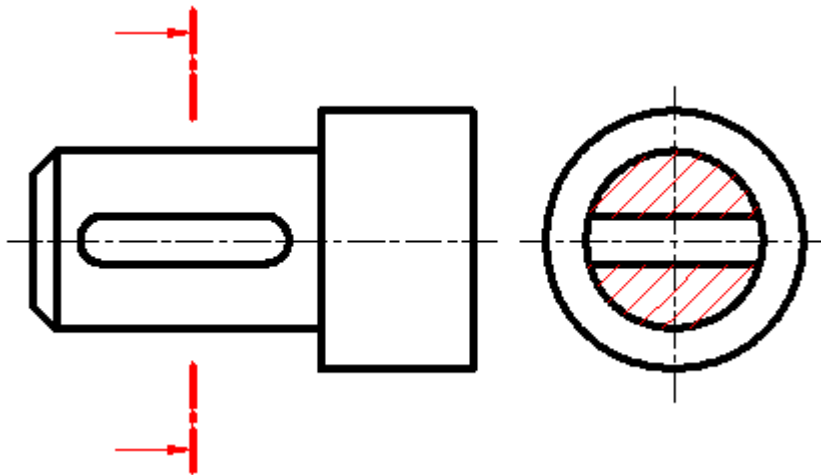
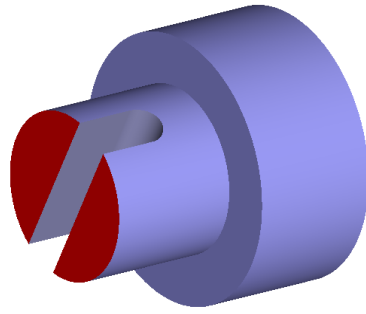
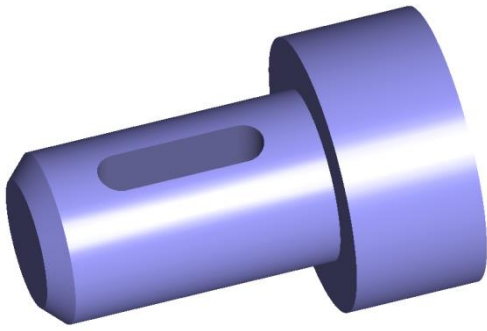

**OTOČENÝ PRŮŘEZ**

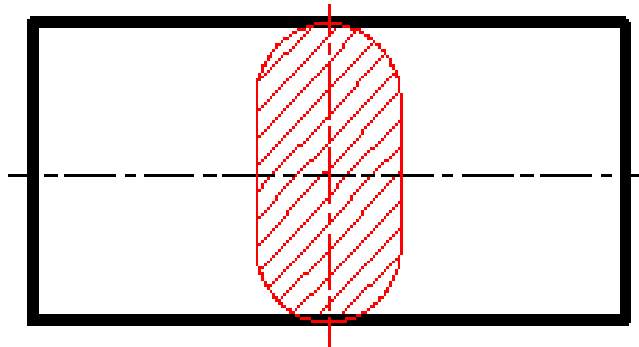
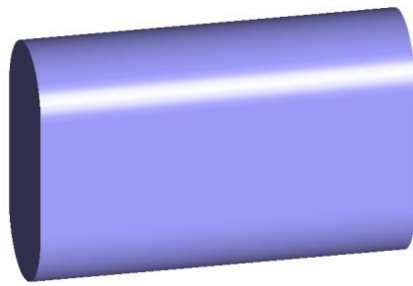

**OTOČENÝ VYSUNUTÝ PRŮŘEZ**

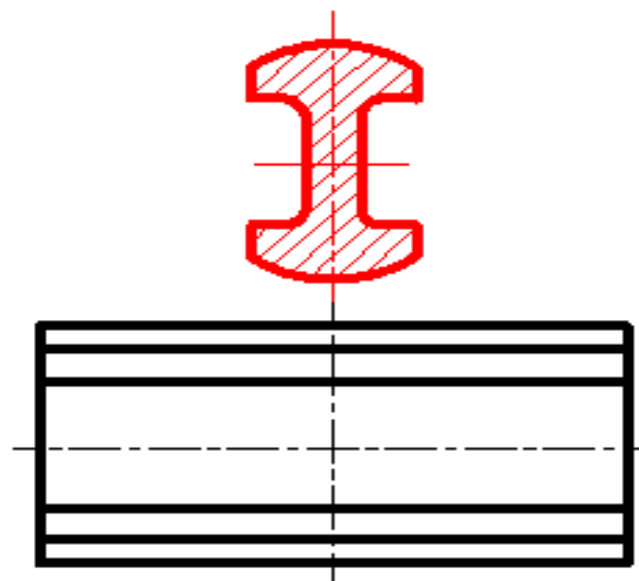
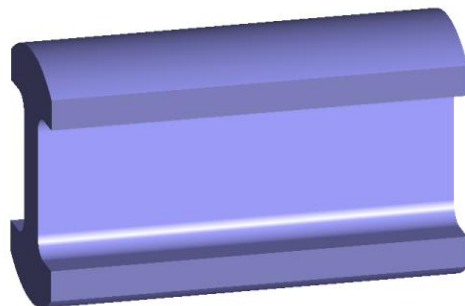

# OTOČENÝ VYSUNUTÝ PRŮŘEZ

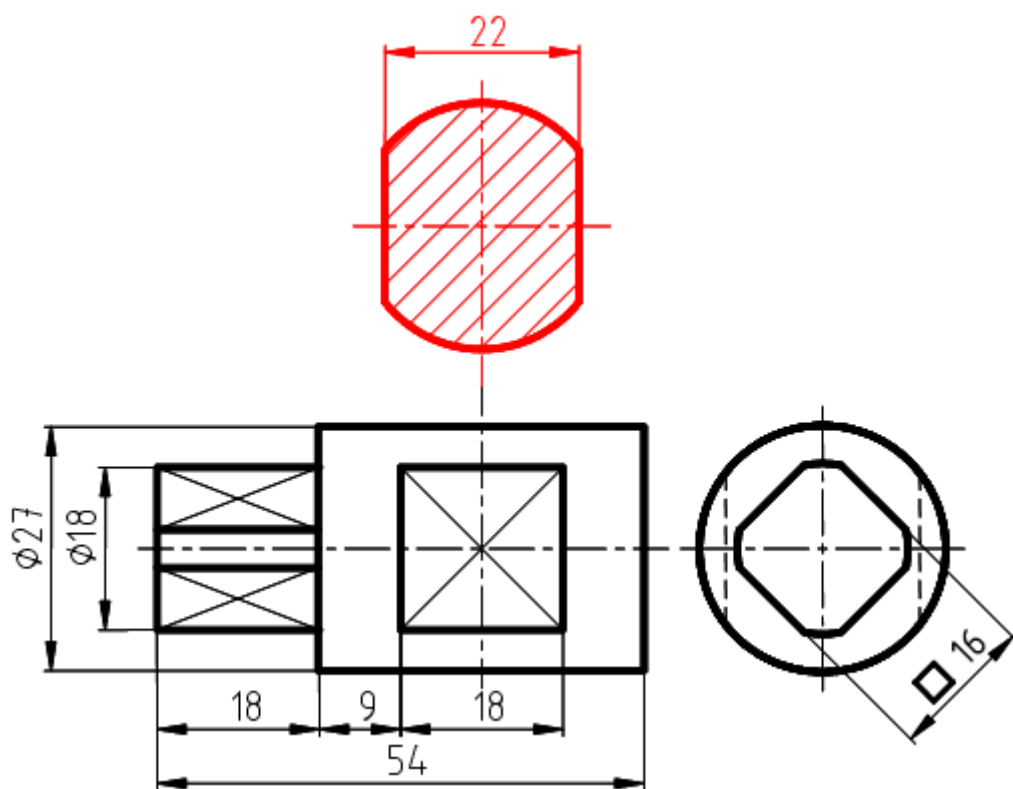
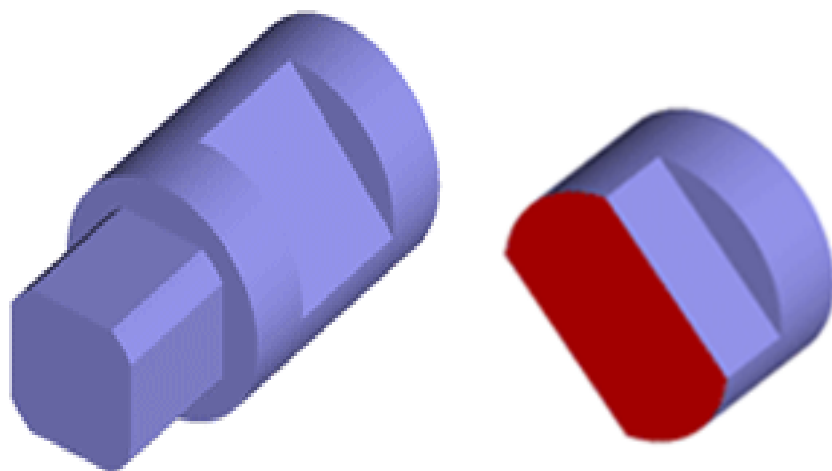

## PRŮŘEZ JAKO SAMOSTATNÝ POHLED

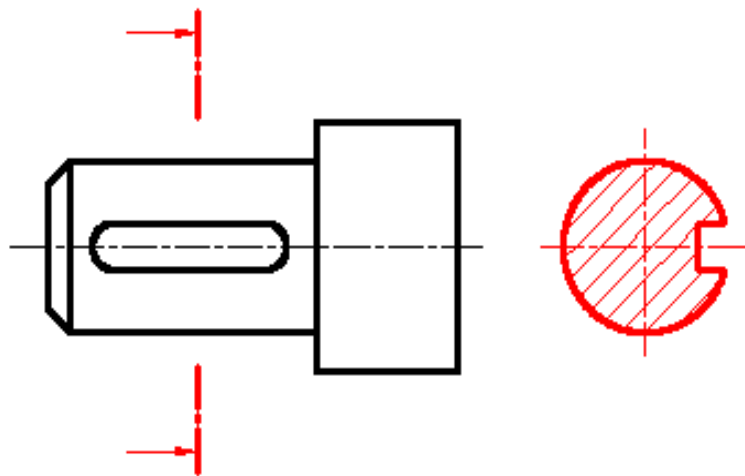
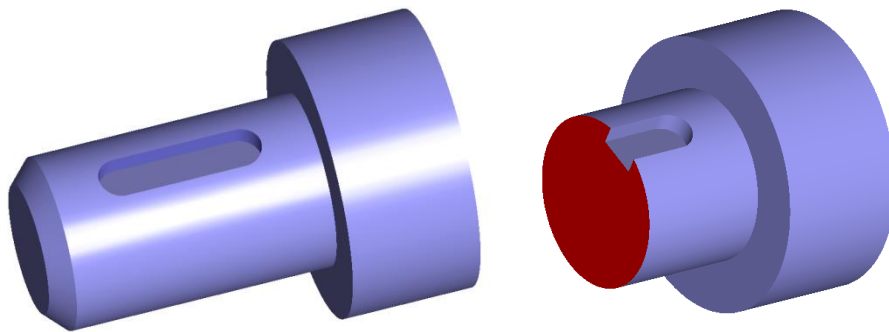

## PRŮŘEZ KRESLENÝ V PŘERUŠENÉM OBRAZU SOUČÁSTI – JE-LI DOST MÍSTA

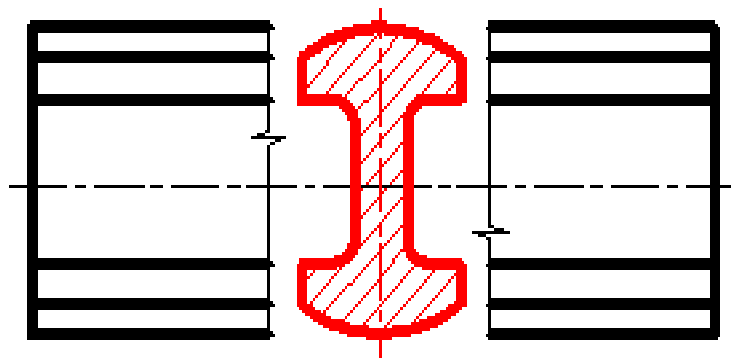
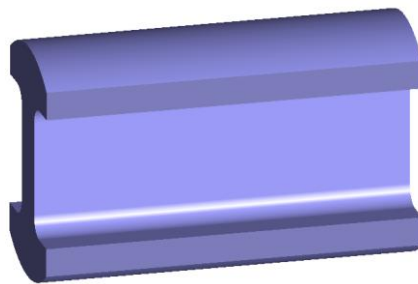

## **CVIČENÍ 6**

### **KÓTOVÁNÍ - ÚVOD**

## KÓTOVÁNÍ

- Kótování – jednoznačné určení rozměrů a umístění všech tvarových podrobností zobrazeného předmětu
- Základní druhy kót – délková, poloměrová, průměrová, úhlová

délková kóta

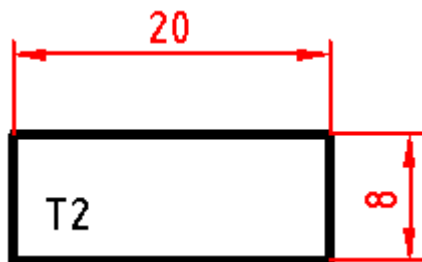

průměrová kóta

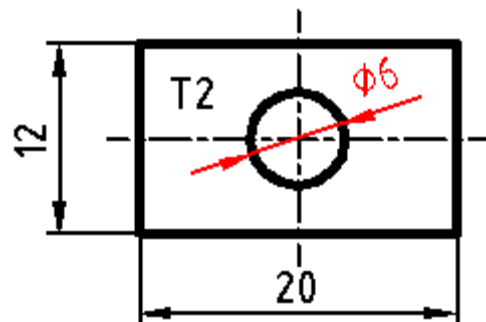

poloměrová kóta

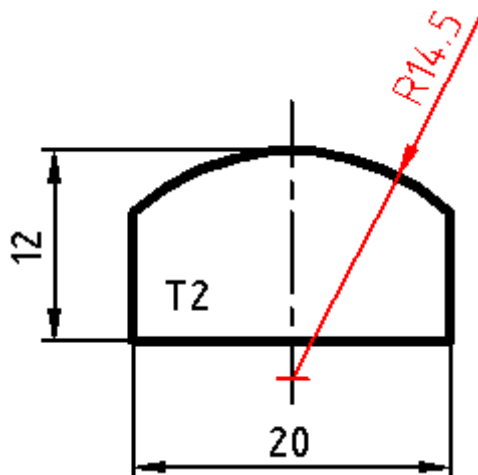

úhlová kóta

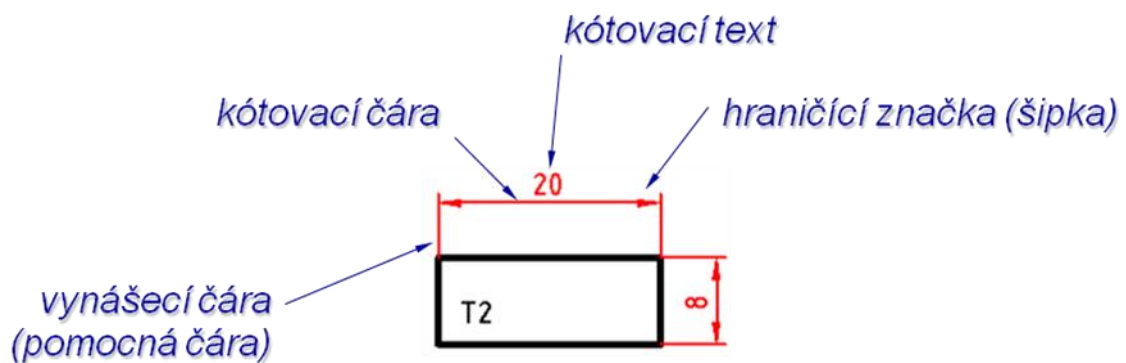
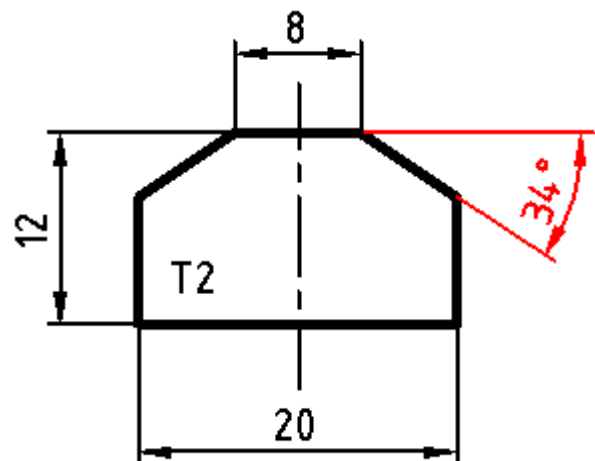

OKÓTUJTE

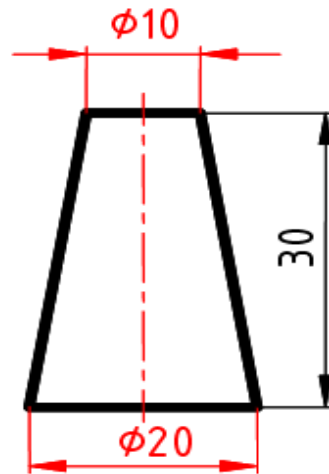
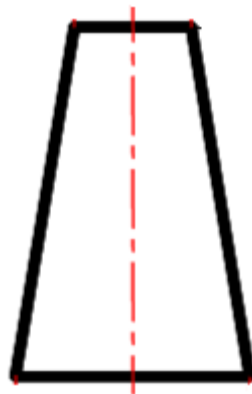
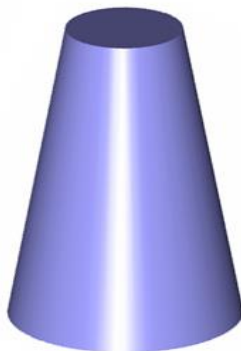
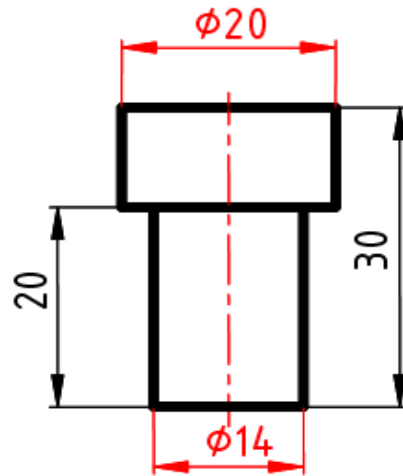
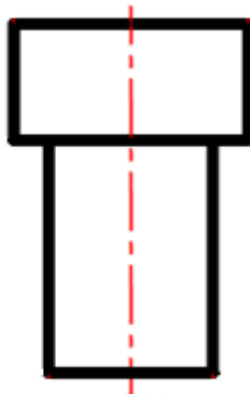
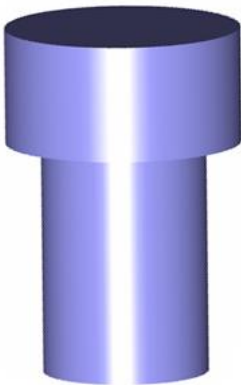
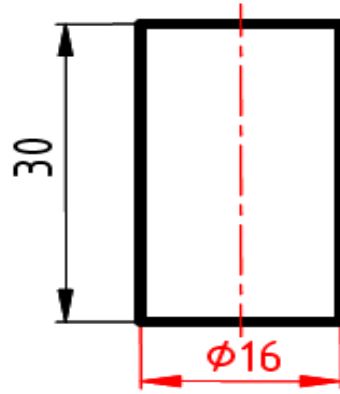
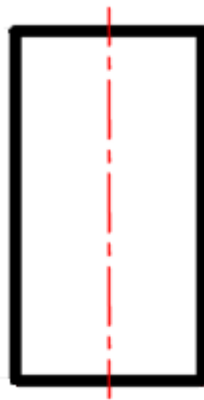
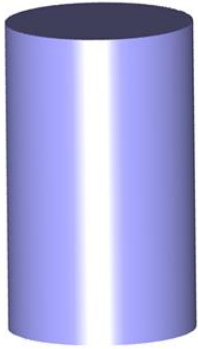



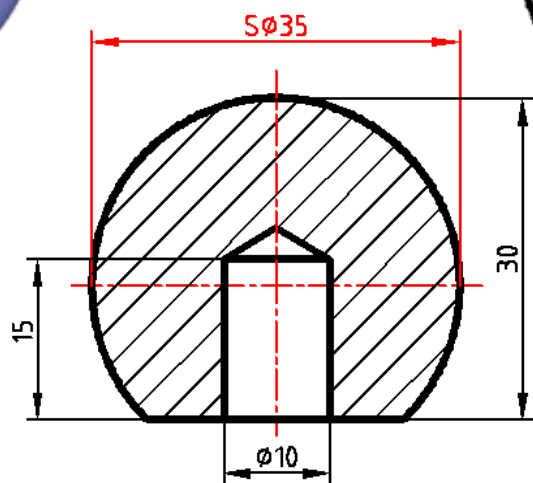
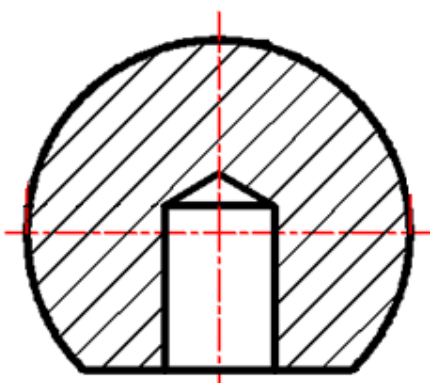
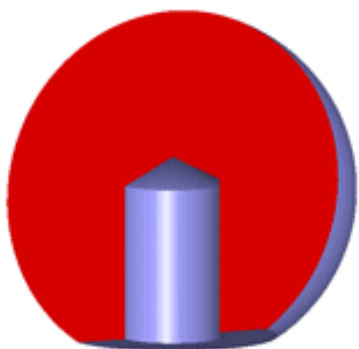
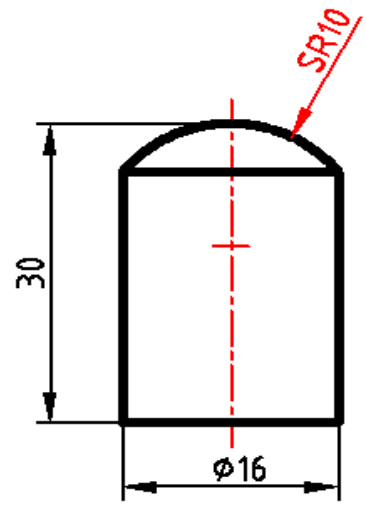
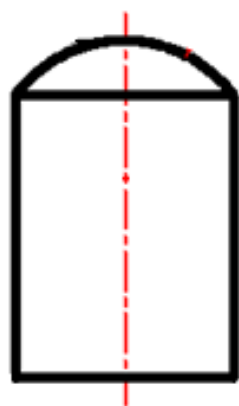
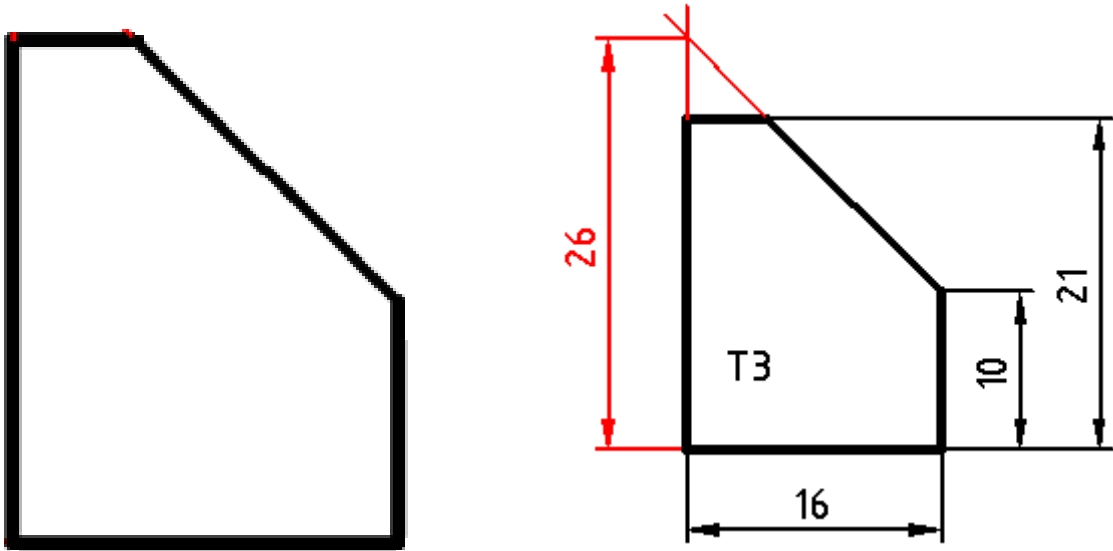

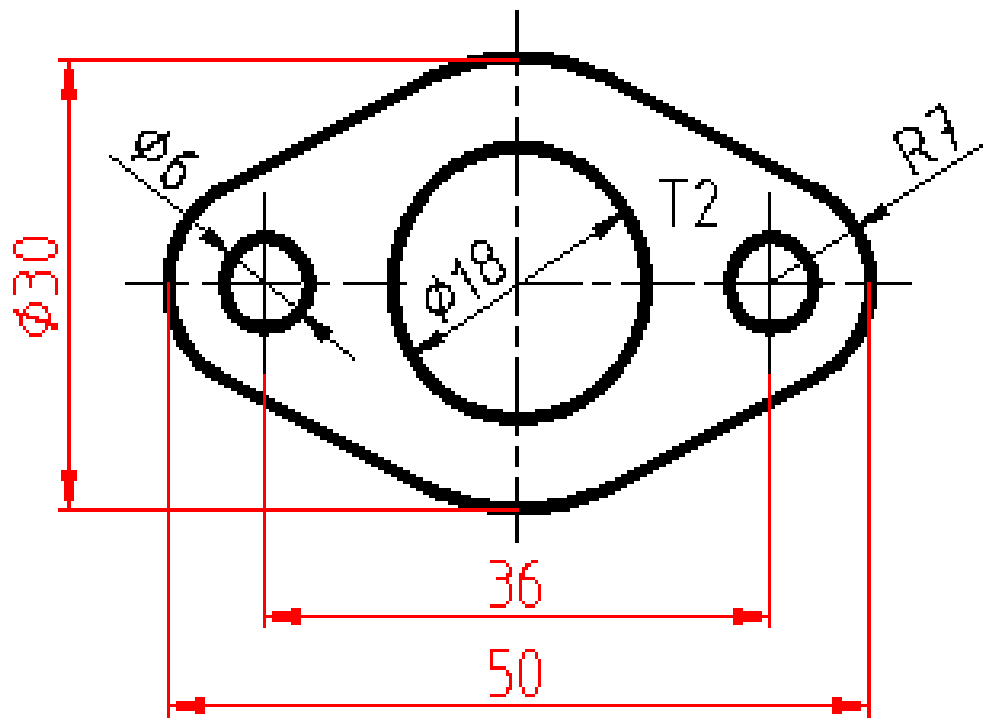
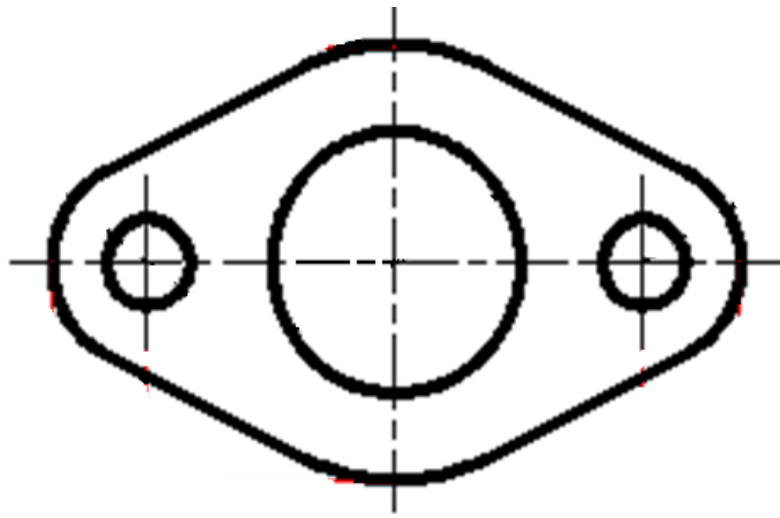
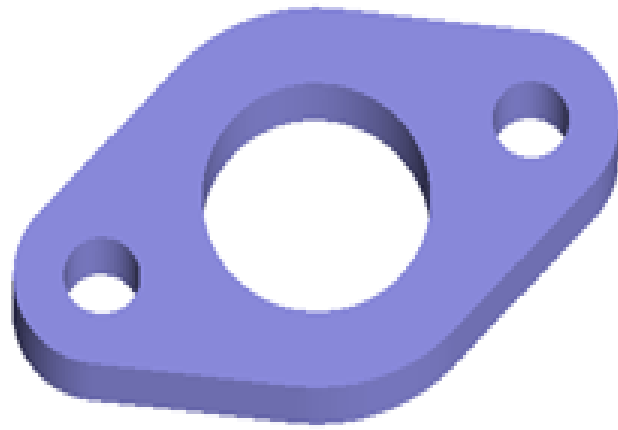

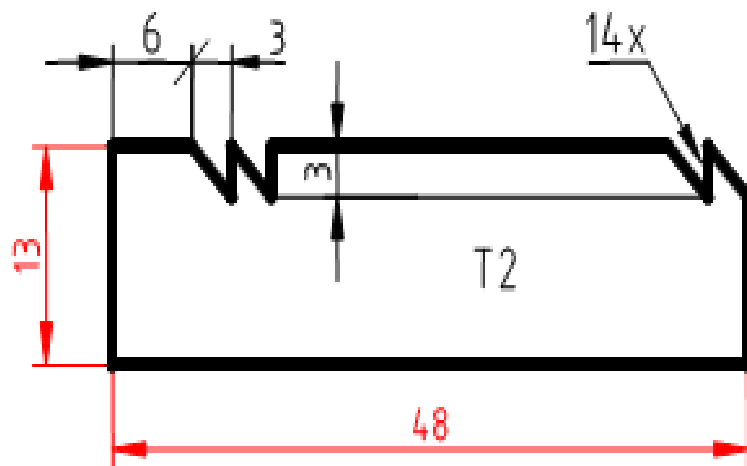
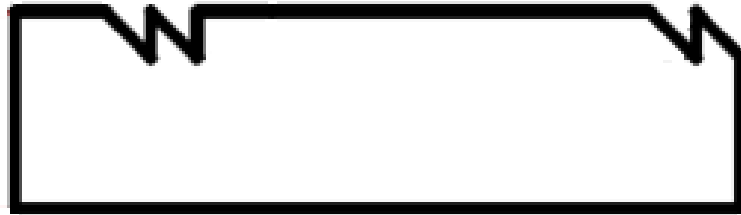

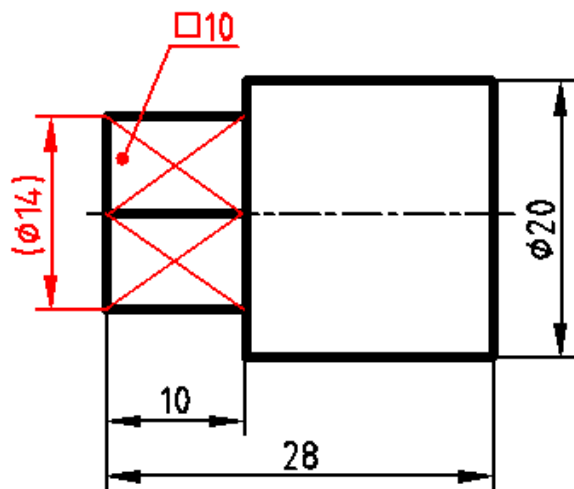
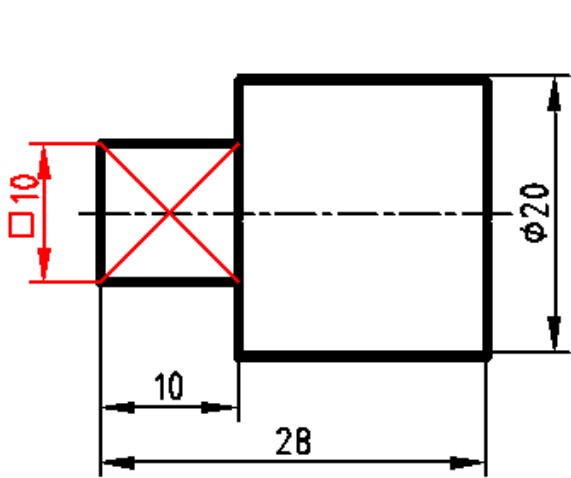
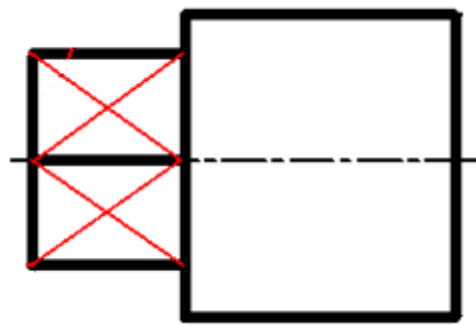
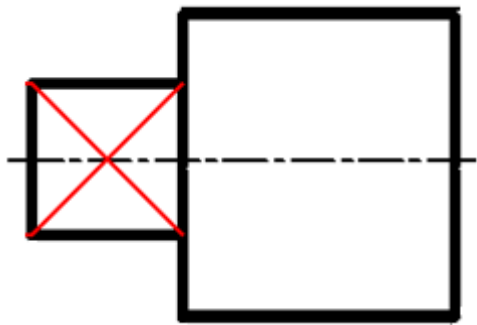
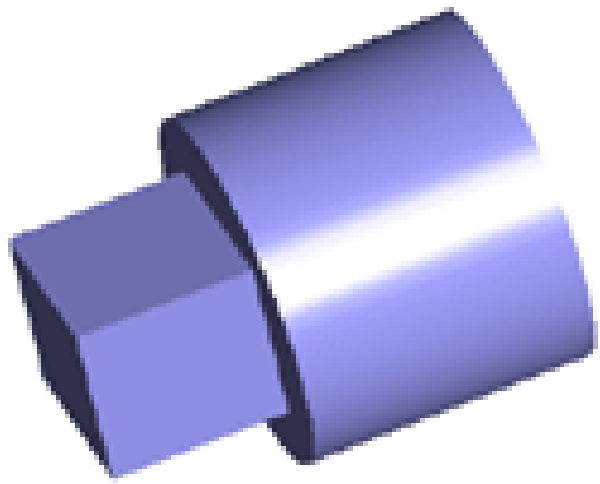

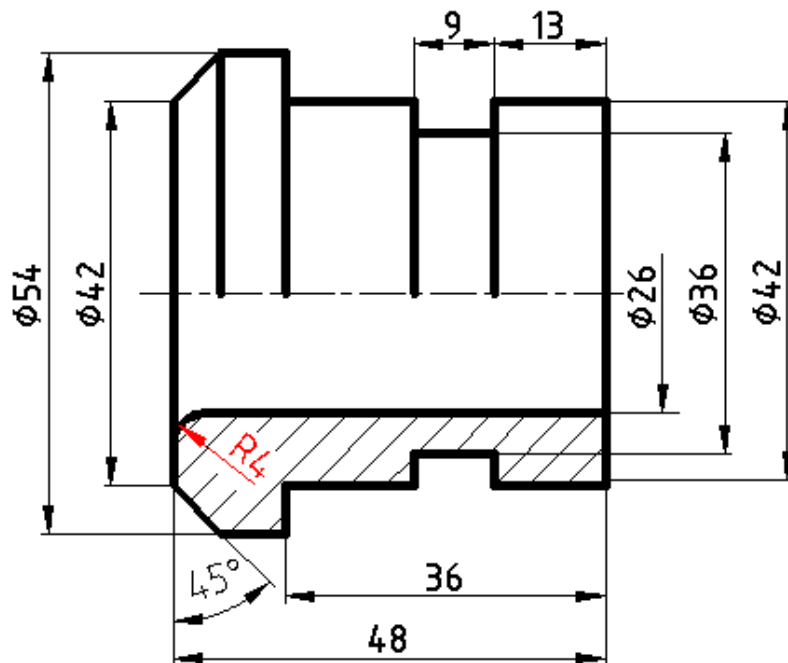
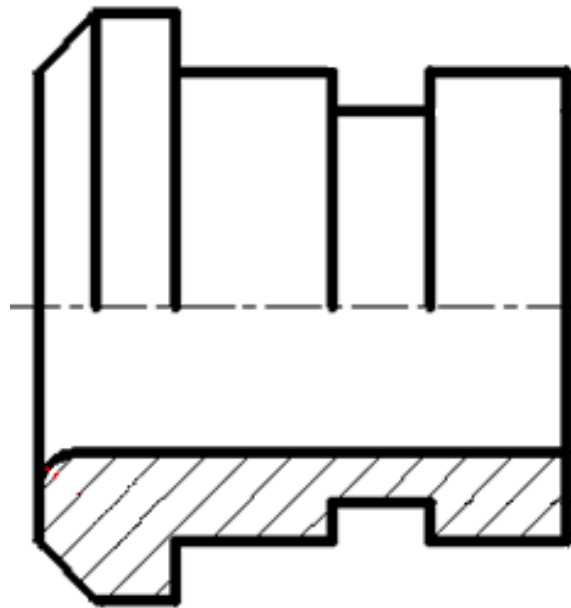
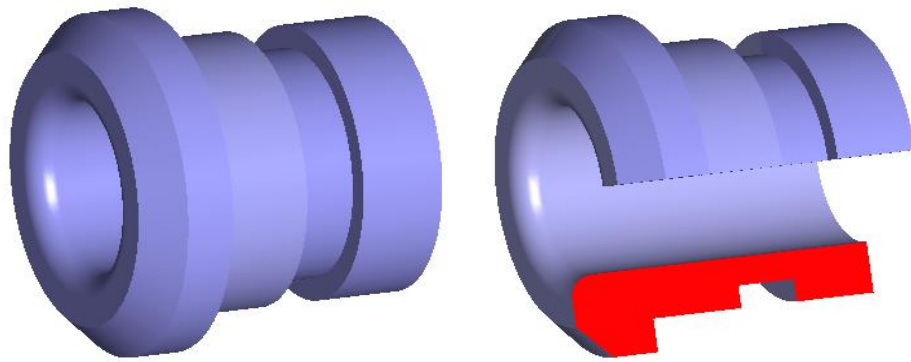

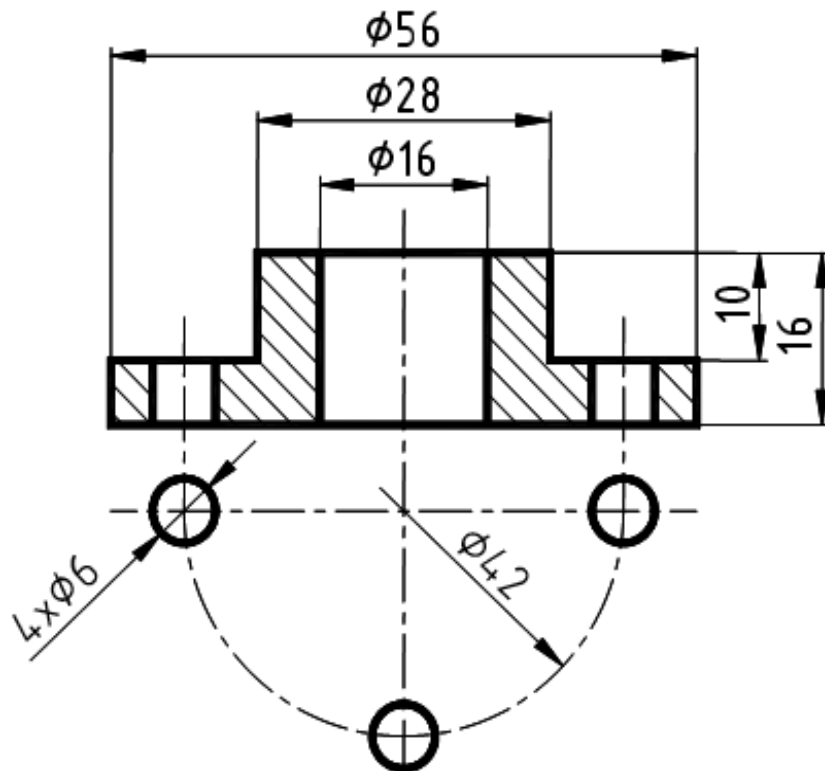
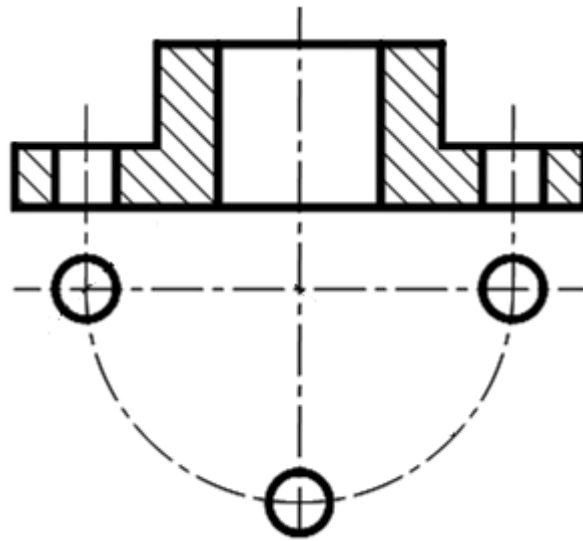
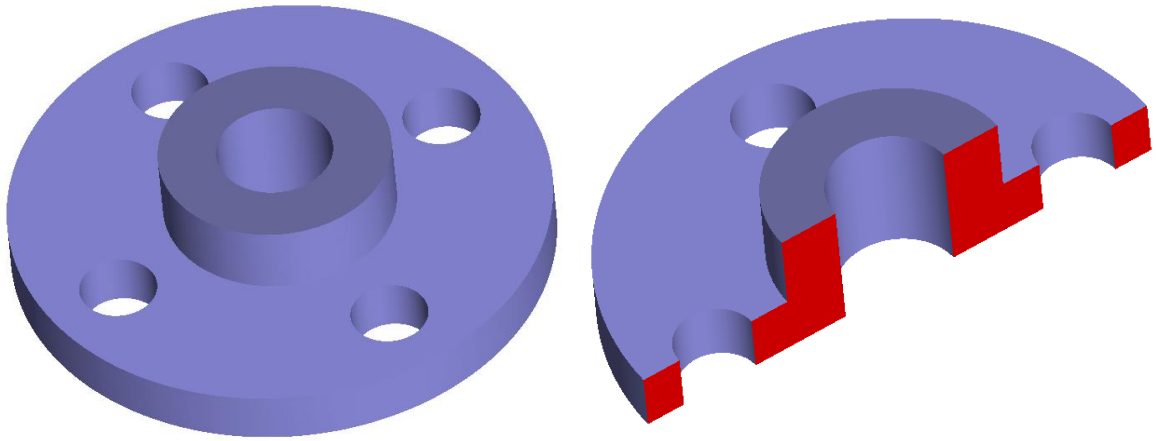

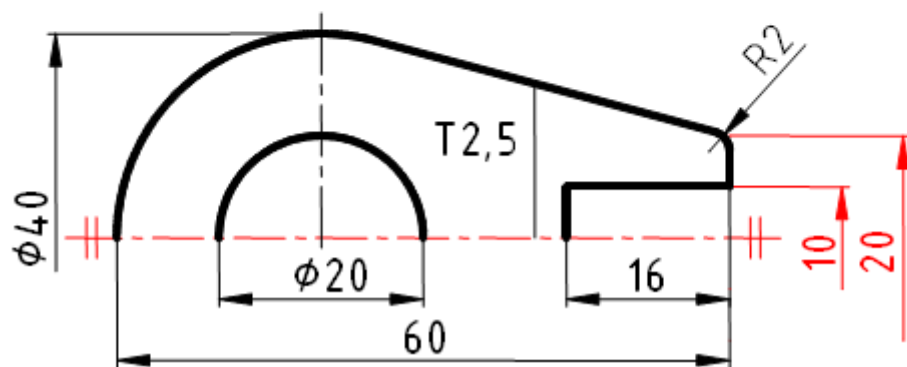
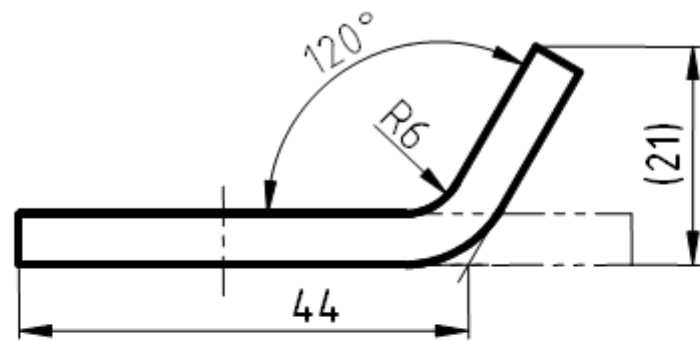
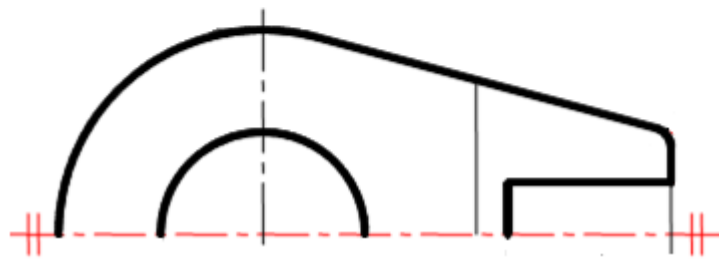
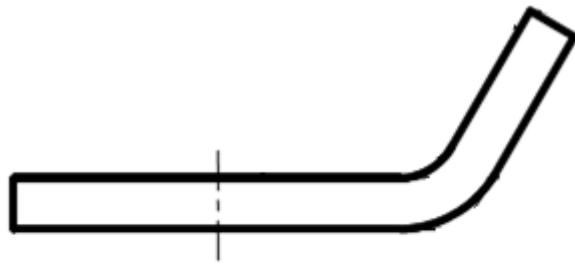



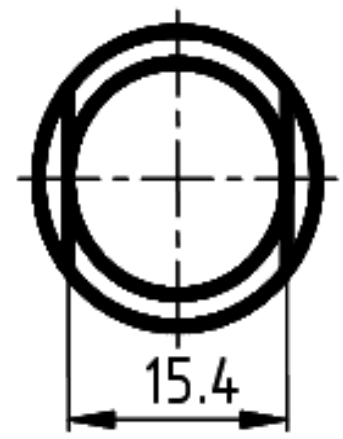
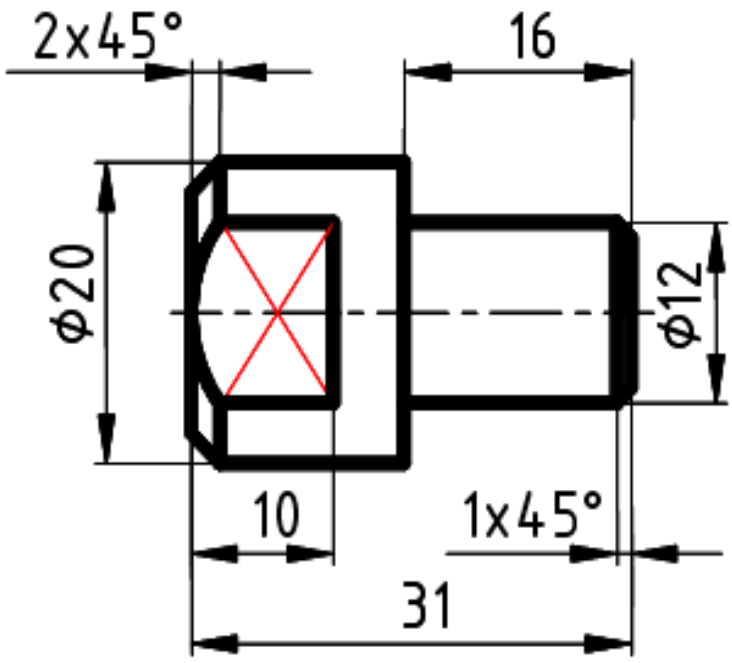
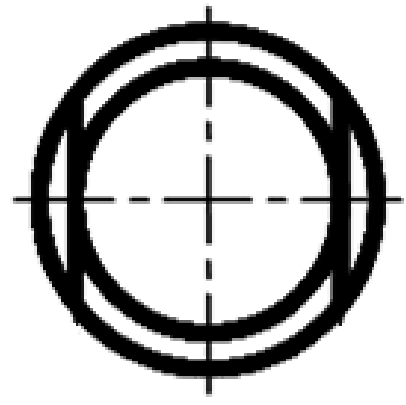
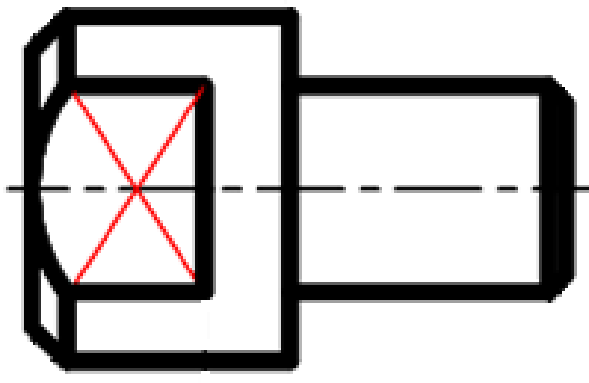
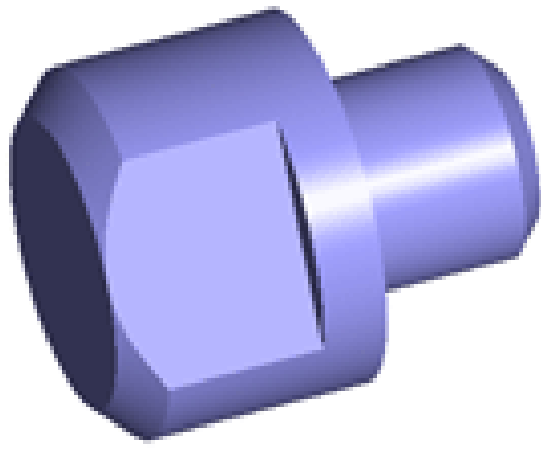



# ŘETĚZCOVÉ KÓTOVÁNÍ

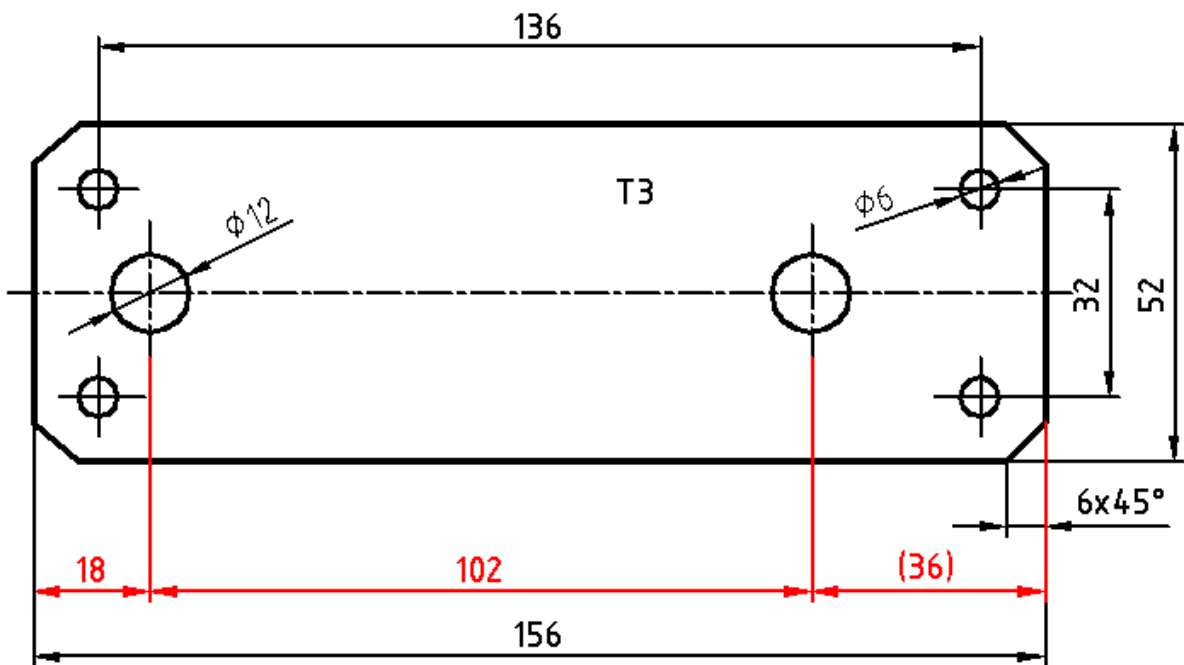
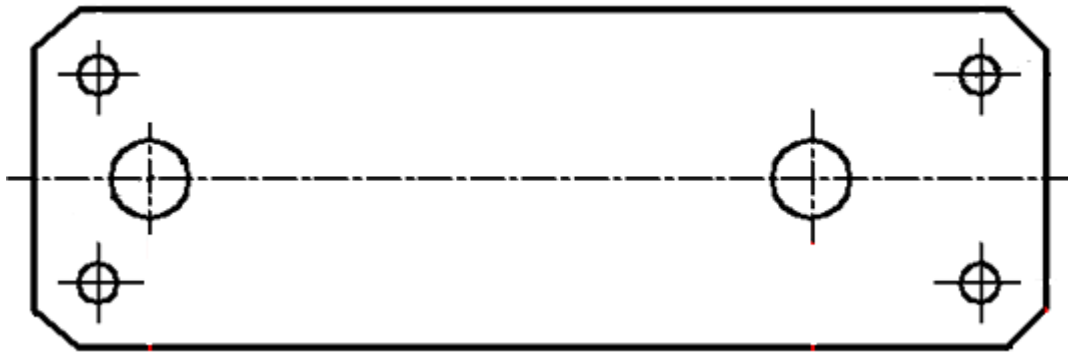

# KÓTOVÁNÍ OD SPOLEČNÉ ZÁKLADNY

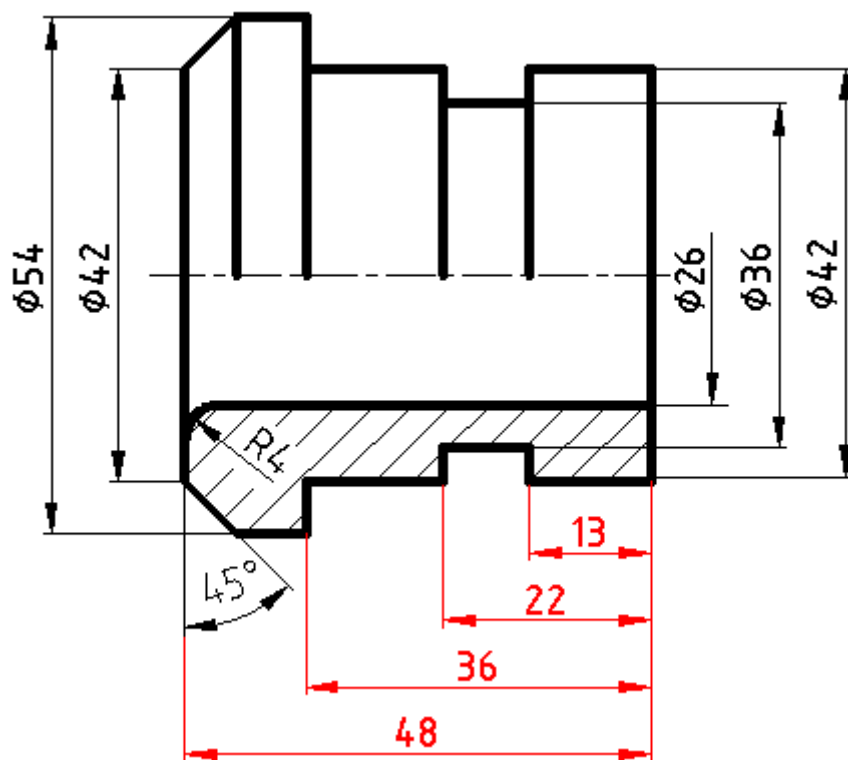
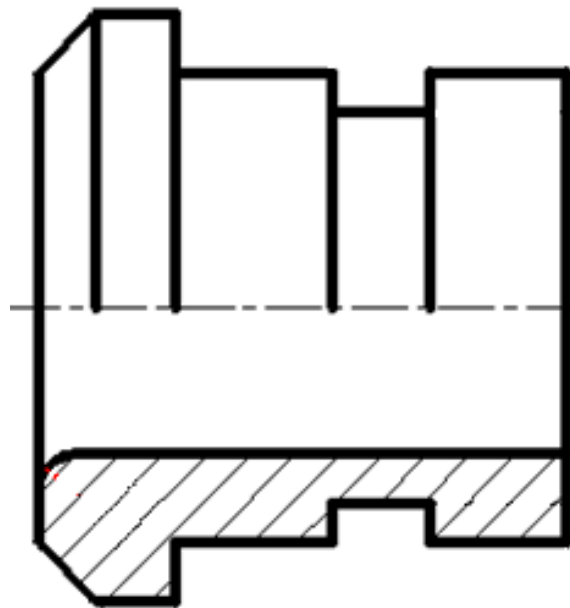

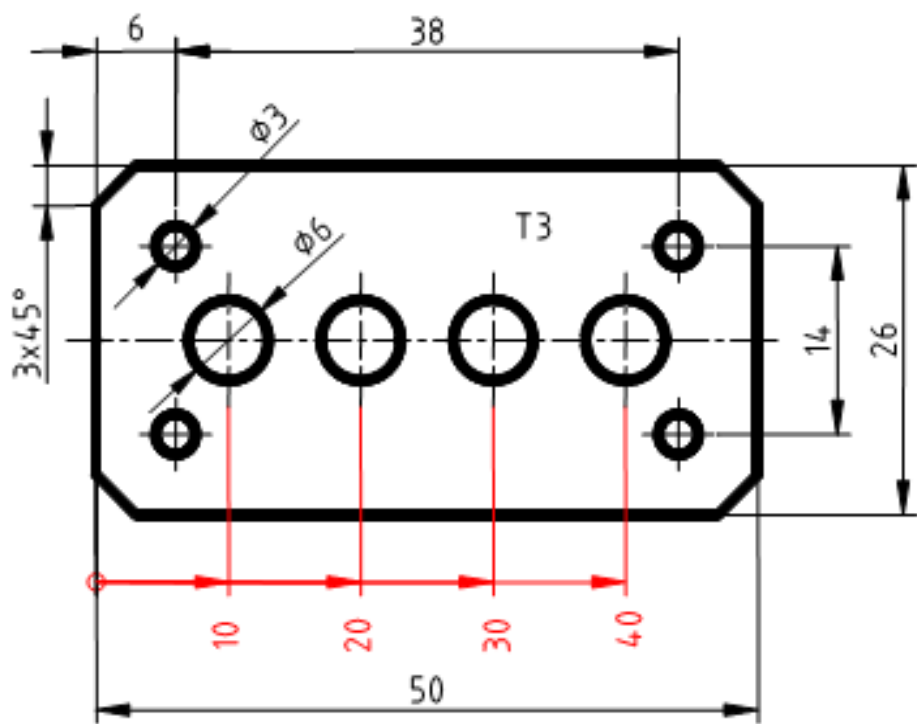
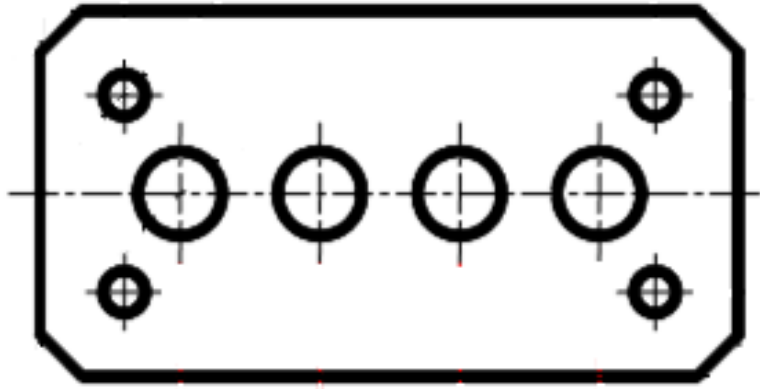



# **CVIČENÍ 7**

## **KÓTOVÁNÍ**



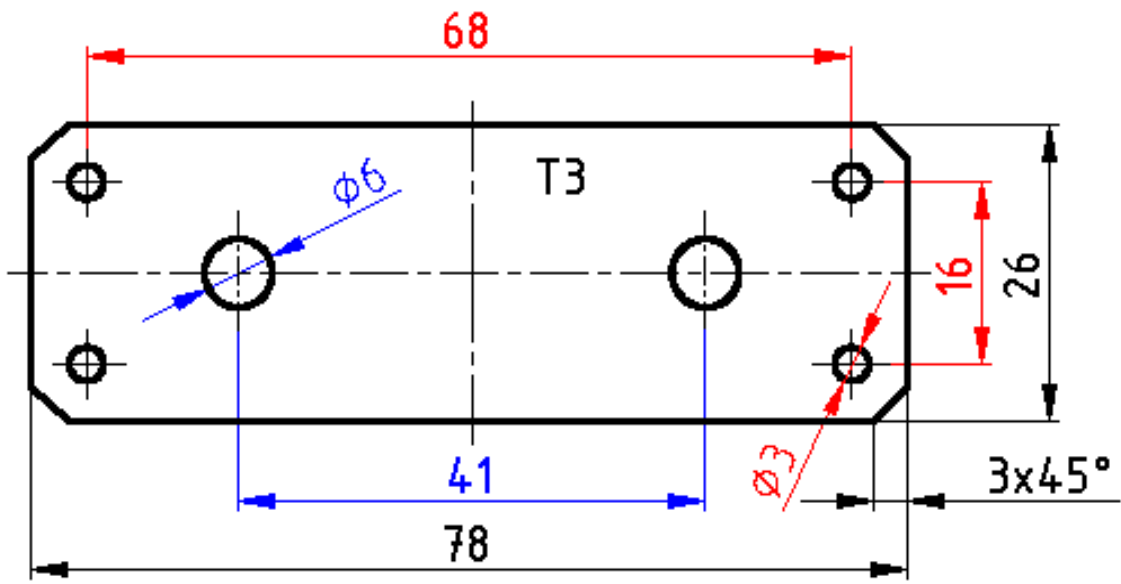
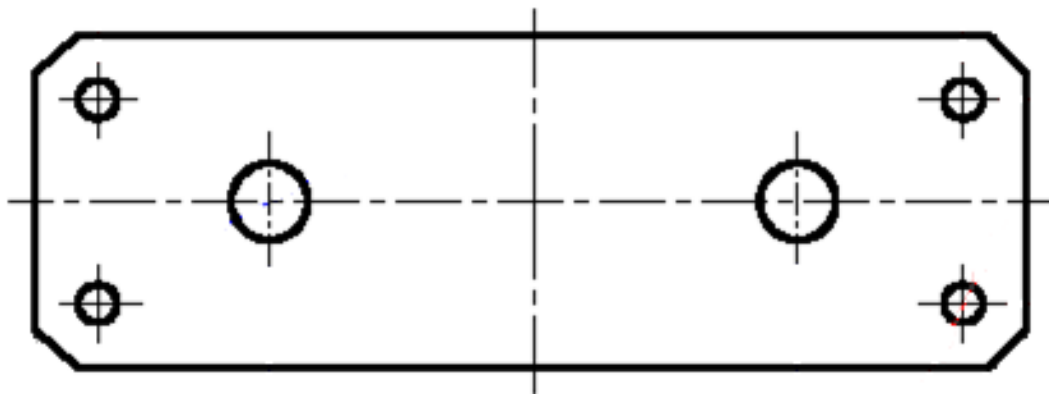

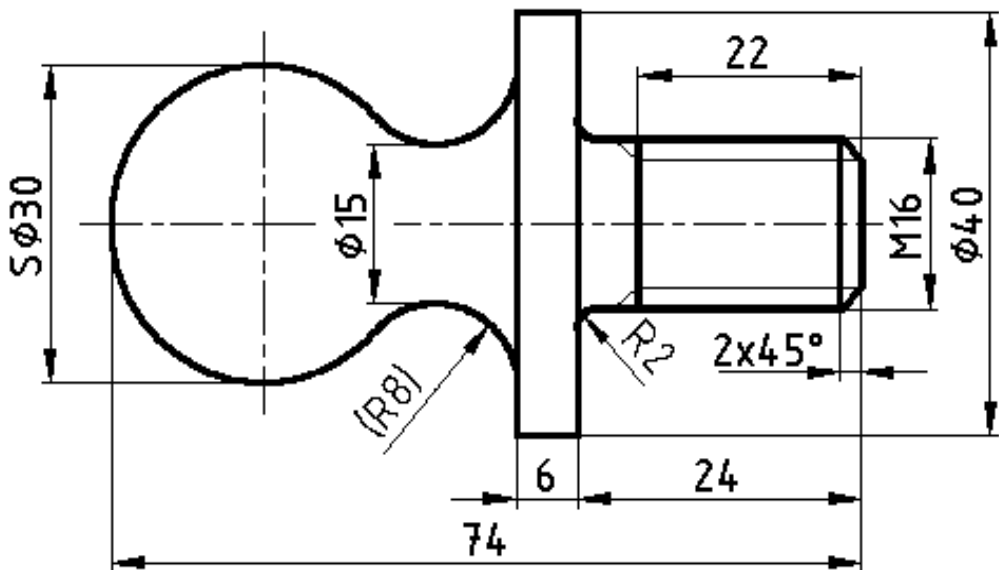
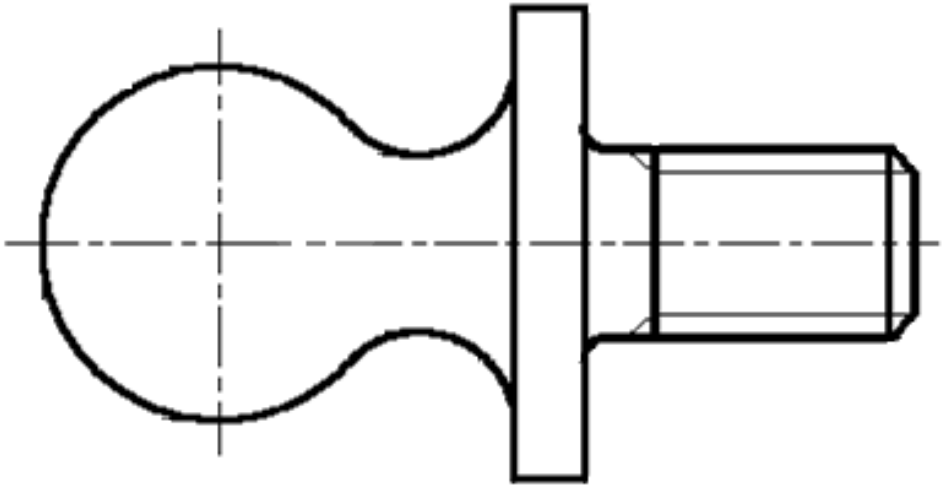
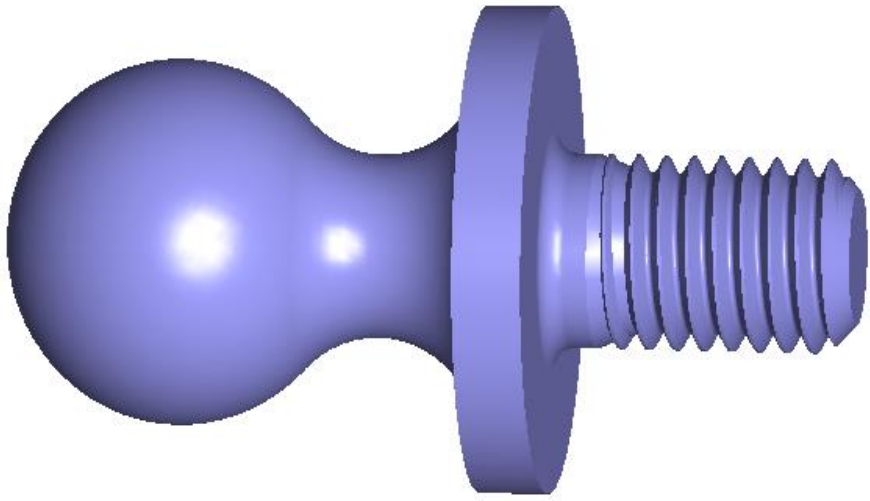

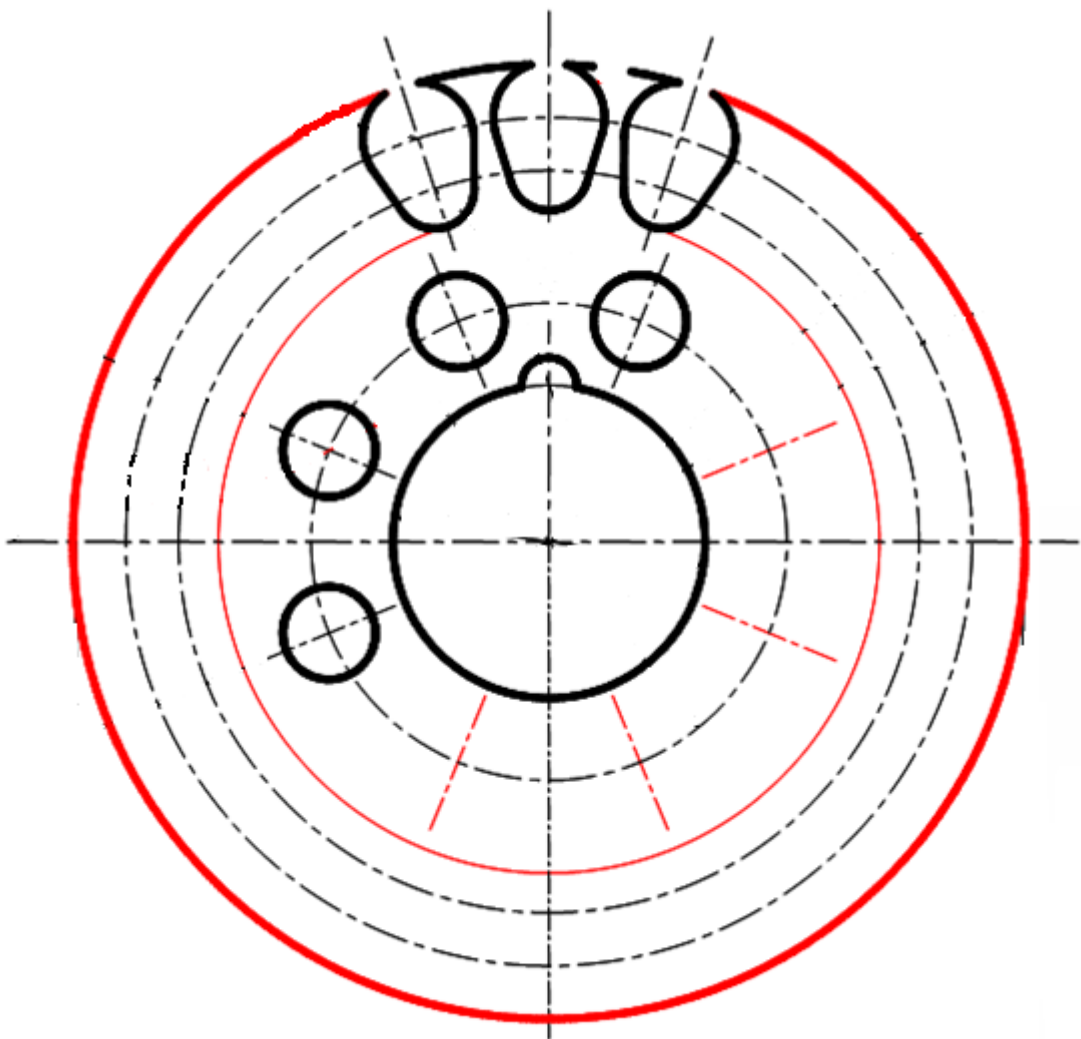
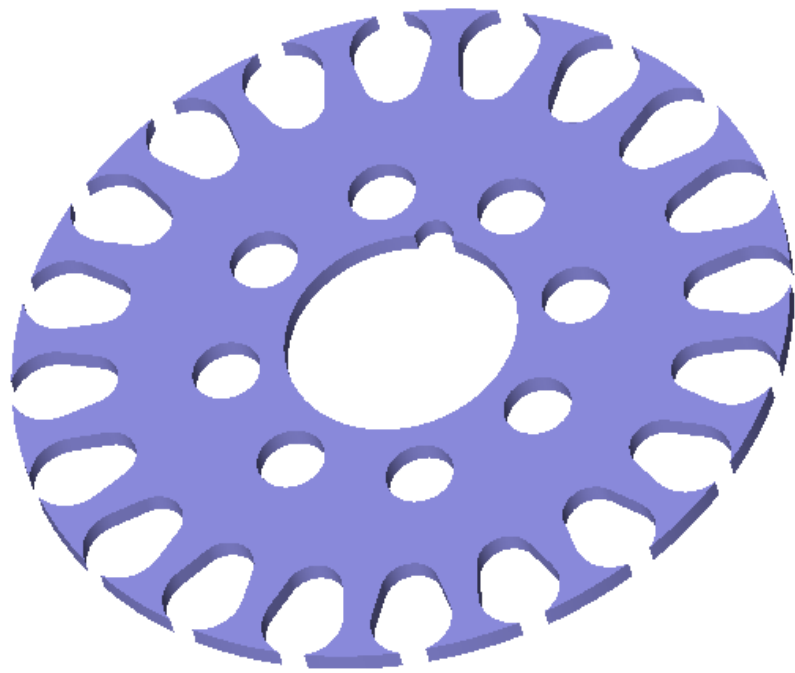

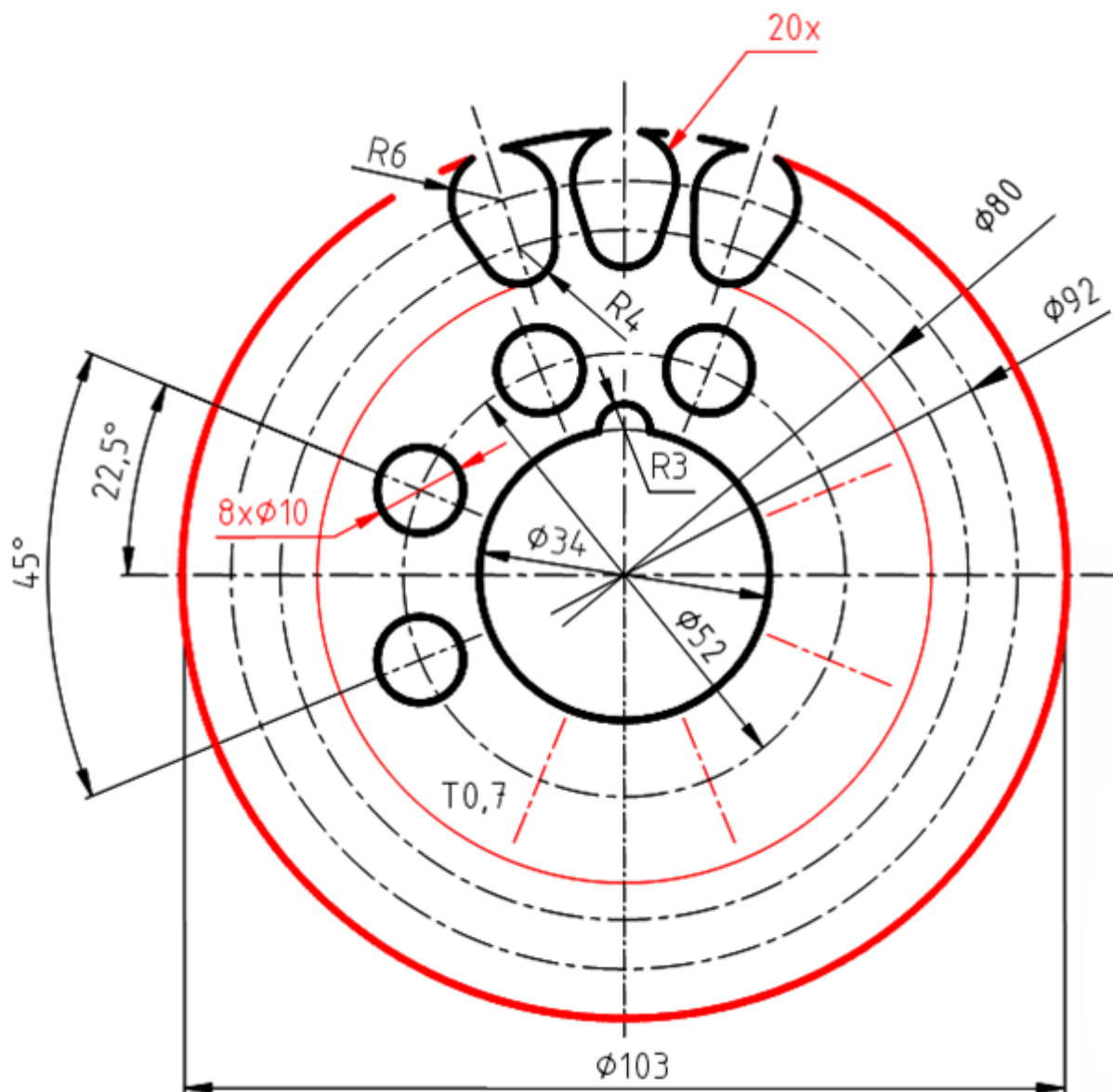

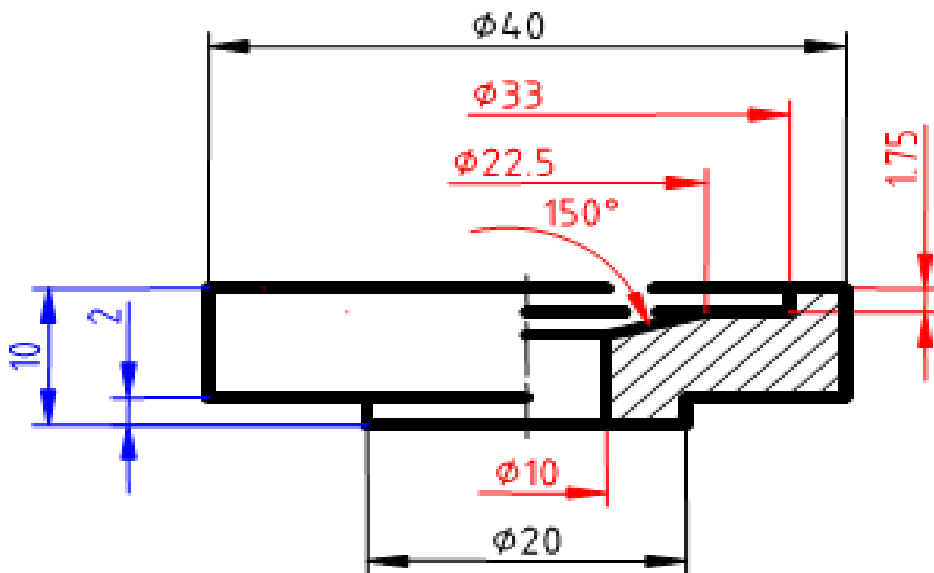
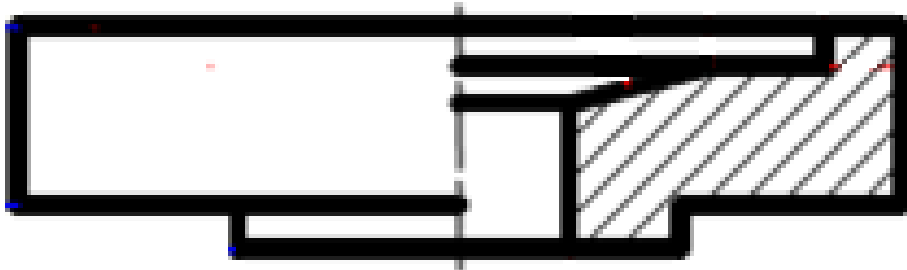
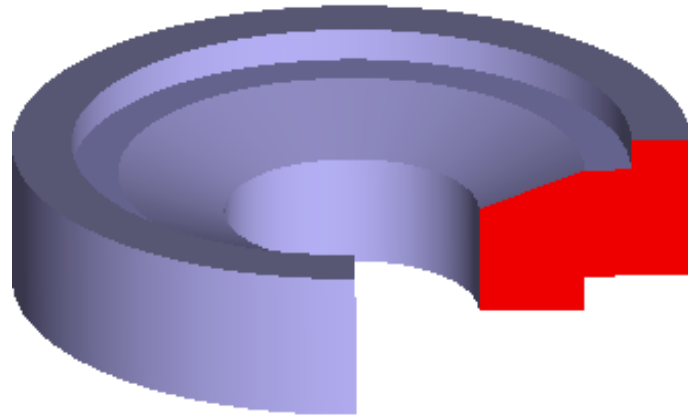

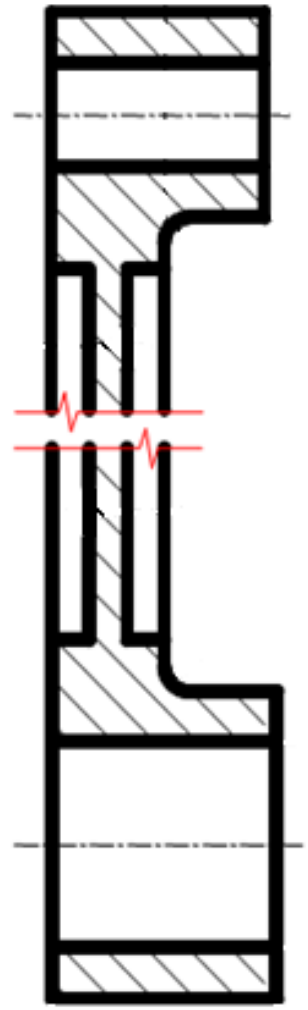
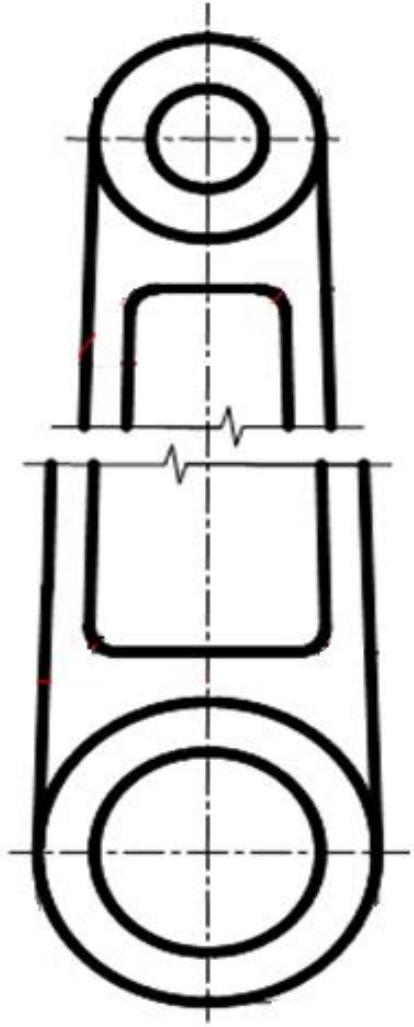
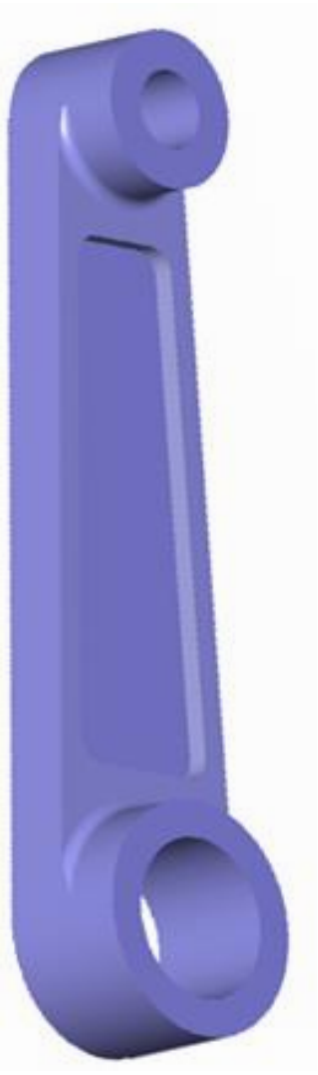

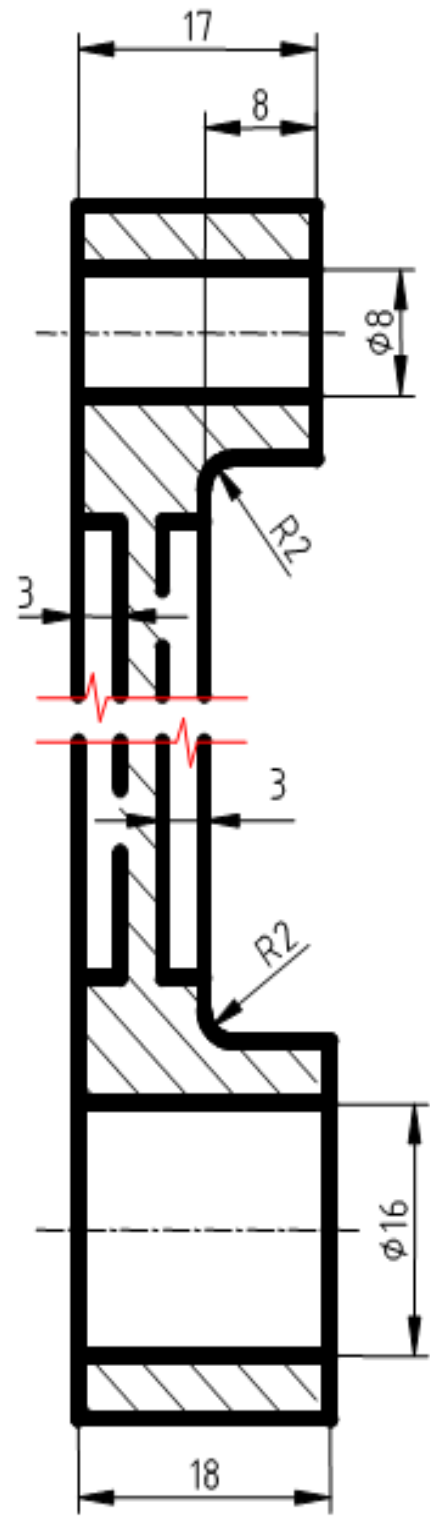
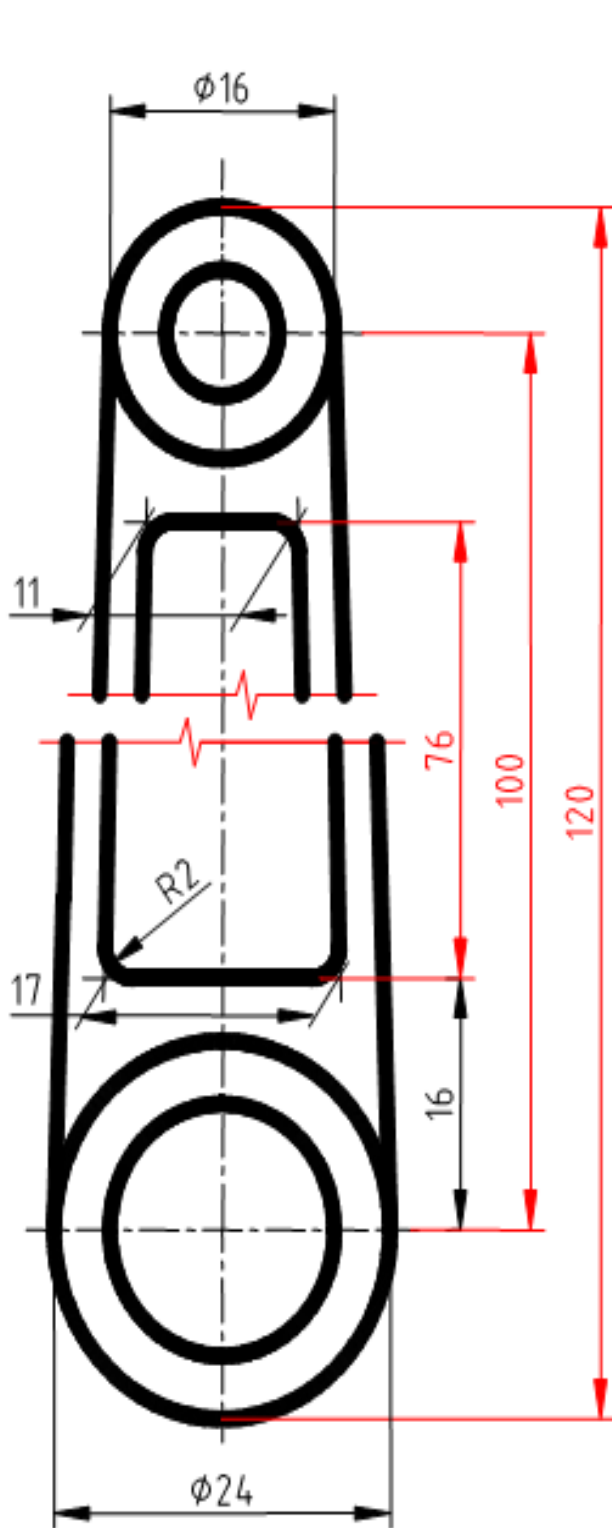

## **CVIČENÍ 8**

### **PŘEDEPISOVÁNÍ PŘESNOSTI ROZMĚRU**



## PŘEDEPISOVÁNÍ PŘESNOSTI ROZMĚRU

*jmenovité rozměry*

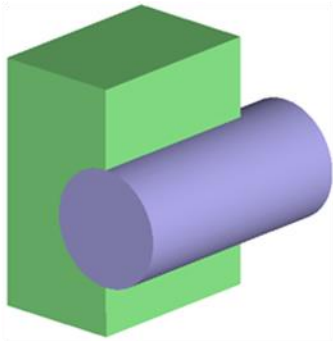

*skutečné rozměry*

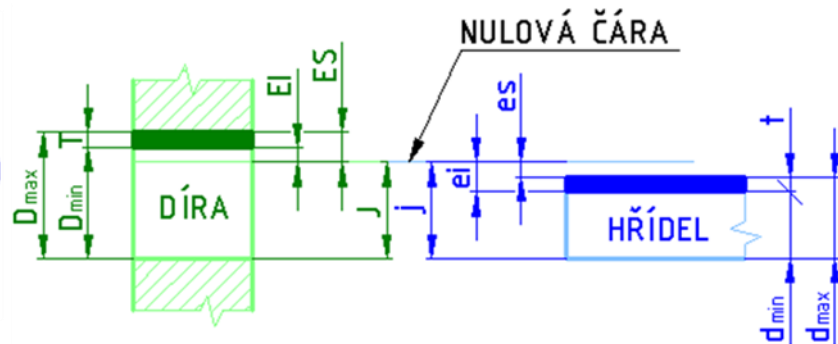
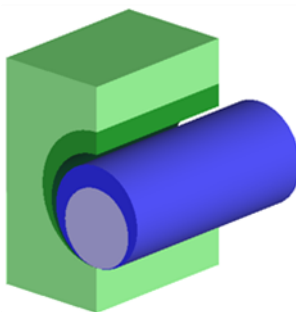
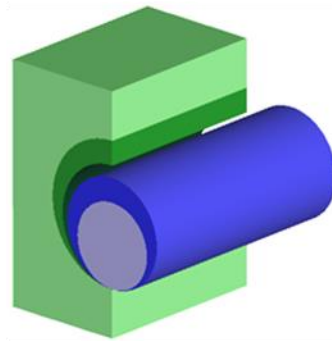

$D_{\max}$  horní mezní rozměr díry  
 $D_{\min}$  dolní mezní rozměr díry  
 $D$  jmenovitý rozměr díry  
 $ES$  horní mezní úchylka díry  
 $EI$  dolní mezní úchylka díry  
 $T$  tolerance díry

$d_{\max}$  horní mezní rozměr hřídele  
 $d_{\min}$  dolní mezní rozměr hřídele  
 $d$  jmenovitý rozměr hřídele  
 $es$  horní mezní úchylka hřídele  
 $ei$  dolní mezní úchylka hřídele  
 $t$  tolerance hřídele

## DRUHY ULOŽENÍ

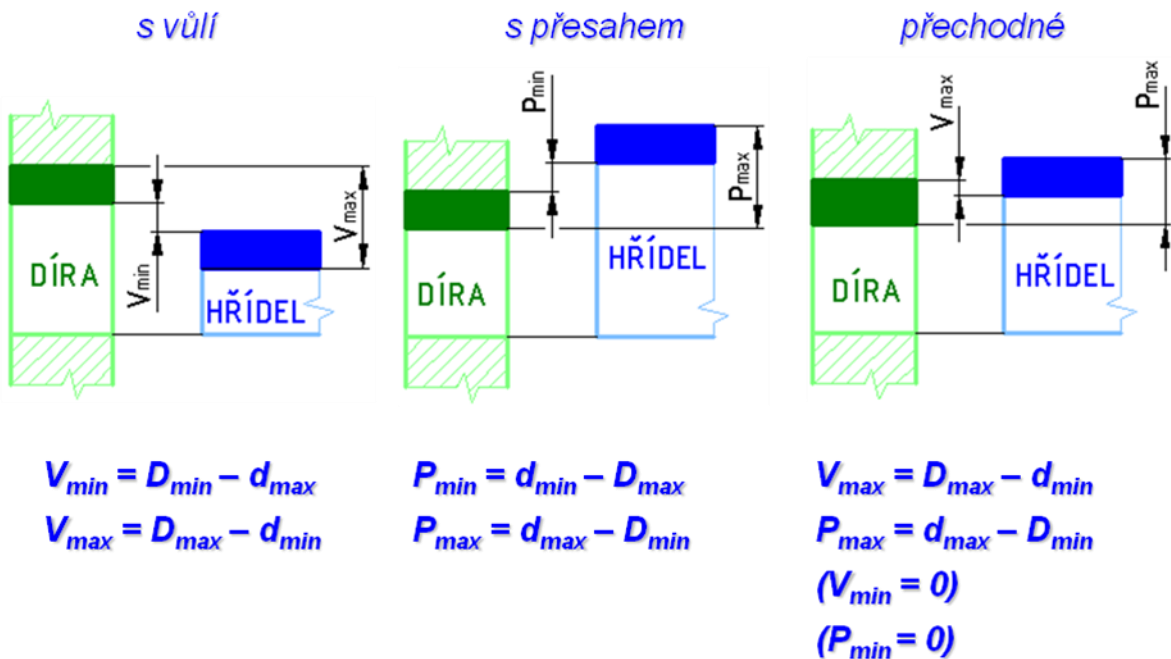

## ULOŽENÍ S VŮLÍ

- V uložení s vůlí je vždy skutečný průměr hřídele menší ( $V_{min} > 0 \mu m$ ) nebo roven ( $V_{min} = 0 \mu m$ ) skutečnému průměru díry
- V grafickém znázornění je toleranční pole díry nad tolerančním polem hřídele ( $V_{min} > 0 mm$ ) nebo se toleranční pole díry dotýká svým spodním okrajem horního okraje tolerančního pole hřídele ( $V_{min} = 0 mm$ )

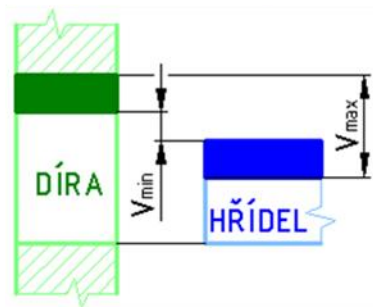

$$V_{min} = D_{min} - d_{max}$$

$$V_{max} = D_{max} - d_{min}$$

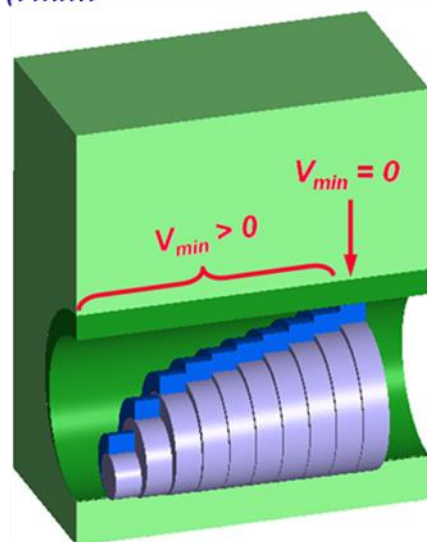

## ULOŽENÍ S PŘESAHEM

- V uložení s přesaheem je vždy skutečný průměr hřídele větší ( $P_{min} > 0 \mu m$ ) nebo roven ( $P_{min} = 0 \mu m$ ) skutečnému průměru díry
- V grafickém znázornění je toleranční pole díry pod tolerančním polem hřídele ( $P_{min} > 0 \mu m$ ) nebo se toleranční pole díry dotýká svým horním okrajem dolního okraje tolerančního pole hřídele ( $P_{min} = 0 \mu m$ )

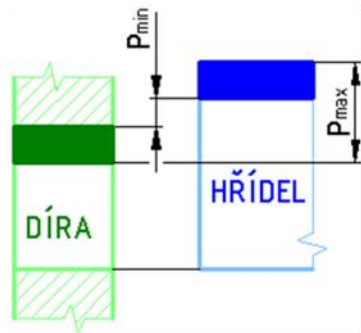

$$P_{min} = d_{min} - D_{max}$$

$$P_{max} = d_{max} - D_{min}$$

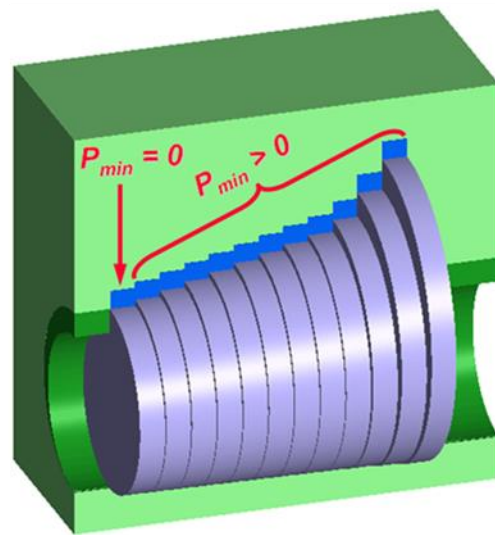

## POLOHA TOLERANČNÍCH POLÍ DĚR A HŘÍDELŮ VZHLEDEM K NULOVÉ ČÁŘE

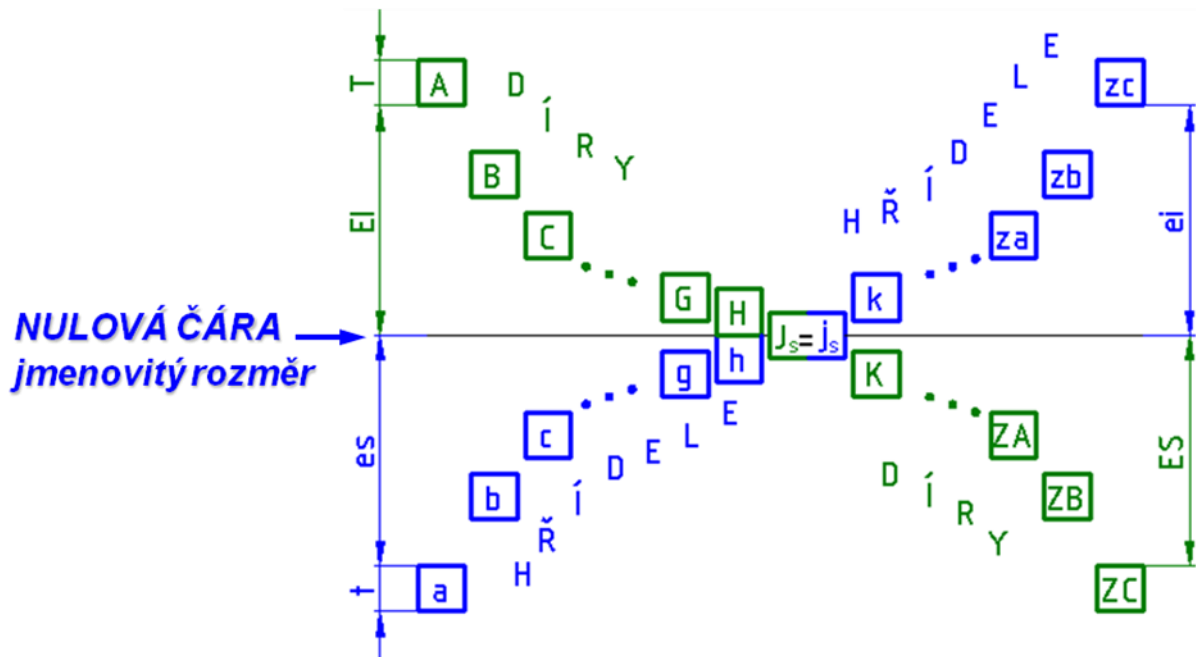

## POLOHA TOLERANČNÍCH POLÍ DĚR A HŘÍDELŮ

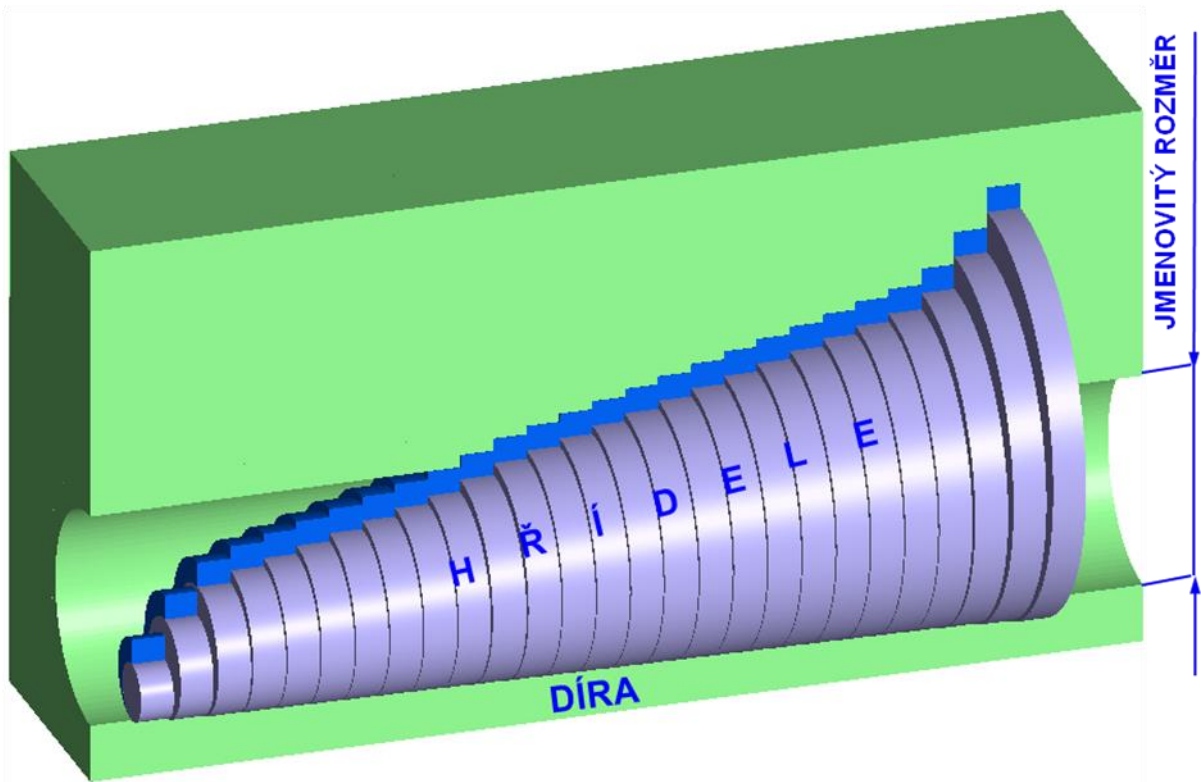

SOUSTAVA JEDNOTNÉ DÍRY

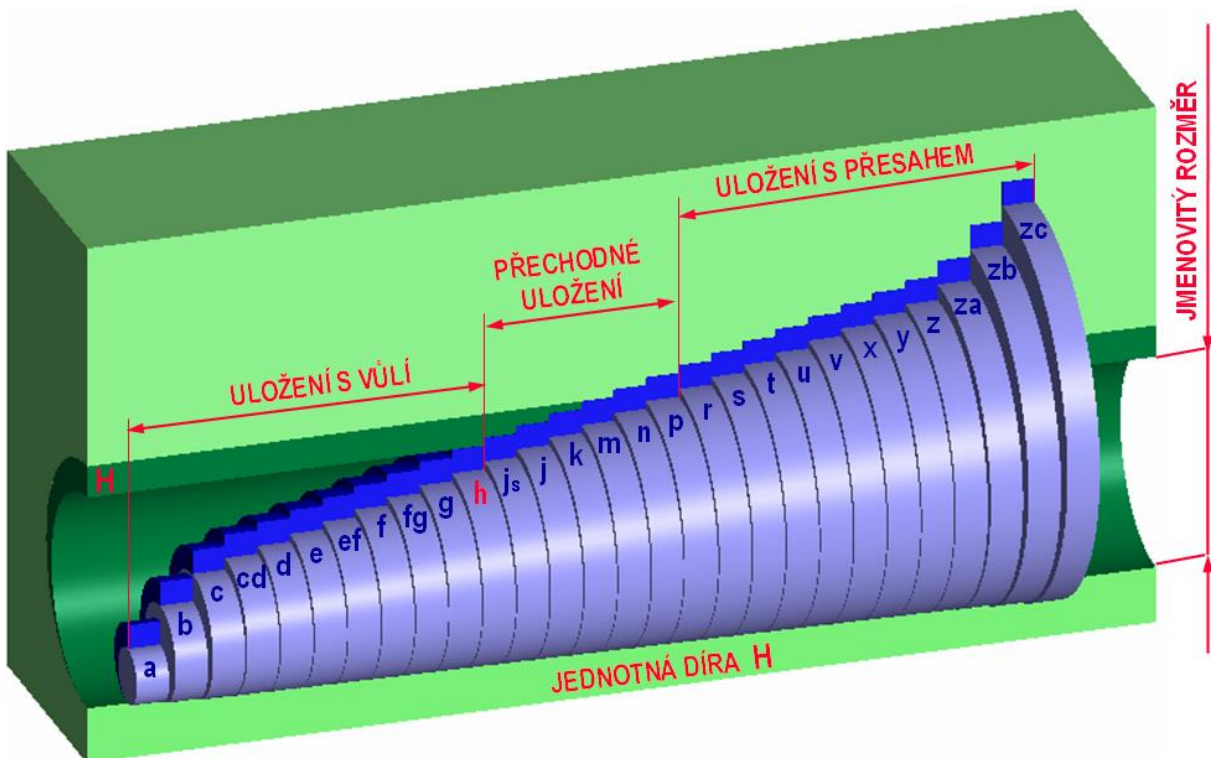

JEDNOTNÁ DÍRA	DÍRY A HŘÍDELE	JMENOVITÉ ROZMĚRY PŘES - DO [mm]													
		PŘES - DO 3	3 6	6 10	10 14	14 18	18 24	24 30	30 40	40 50	50 65	65 80	80 100	100 120	
		MEZNÍ ÚCHYLKY [μm]													
H7	H7	+10 0	+12 0	+15 0	+18 0	+21 0	+25 0	+30 0	+35 0						
	e8	-14 -28	-20 -38	-25 -47	-32 -59	-40 -73	-50 -89	-60 -106	-72 -126						
	f7	-6 -16	-10 -22	-13 -28	-16 -34	-20 -41	-25 -50	-30 -60	-36 -71						
	g6	-2 -8	-4 -12	-5 -14	-6 -17	-7 -20	-9 -25	-10 -29	-12 -34						
	h6	0 -6	0 -8	0 -9	0 -11	0 -13	0 -16	0 -19	0 -22						
	js6	+3,0 -3,0	+4,0 -4,0	+4,5 -4,5	+5,5 -5,5	+6,5 -6,5	+8,0 -8,0	+9,5 -9,5	+11,0 -11,0						
	k6	+6 0	+9 +1	+10 +1	+12 +1	+15 +2	+18 +2	+21 +2	+25 +3						
	n6	+10 +4	+16 +8	+19 +10	+23 +12	+28 +15	+33 +17	+39 +20	+45 +23						
	p6	+12 +6	+20 +12	+24 +15	+29 +18	+35 +22	+42 +26	+51 +32	+59 +37						
	r6	+16 +10	+23 +15	+28 +19	+34 +23	+41 +28	+50 +34	+60 +41	+62 +43	+73 +51	+76 +54				
	s6	+20 +14	+27 +19	+32 +23	+39 +28	+48 +35	+59 +43	+72 +53	+78 +59	+93 +71	+101 +79				
H8	H8	+14 0	+18 0	+22 0	+27 0	+33 0	+39 0	+46 0	+54 0						
	d9	-20 -45	-30 -60	-40 -76	-50 -93	-65 -117	-80 -142	-100 -174	-120 -207						
	e8	-14 -28	-20 -38	-25 -47	-32 -59	-40 -73	-50 -89	-60 -106	-72 -126						

### SOUSTAVA JEDNOTNÉHO HŘÍDELE

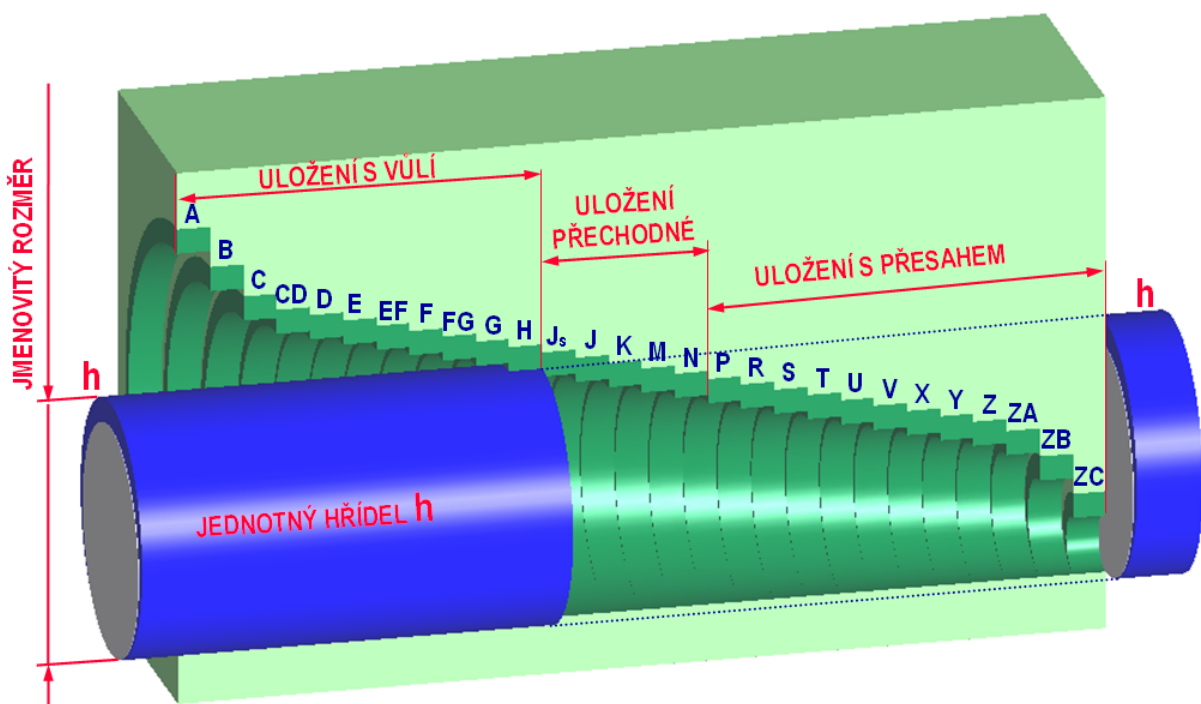

JEDNOTNÝ HŘÍDEL	HŘÍDELE A DÍRY	JMENOVITÉ ROZMĚRY PŘES - DO [mm]																
		PŘES - DO	3 3	6 6	10 10	14 14	18 18	24 24	30 30	40 40	50 50	65 65	80 80	100 100	120 120	140 140	160 160	180 180
		MEZNÍ ÚCHYLKY [μm]																
h6	h6	0 -6	0 -8	0 -9	0 -11	0 -13	0 -16	0 -19	0 -22	0 -25								
	F8	+20 +6	+28 +10	+35 +13	+43 +16	+53 +20	+64 +25	+76 +30	+90 +36	+106 +43								
	H7	+10 0	+12 0	+15 0	+18 0	+21 0	+25 0	+30 0	+35 0	+40 0								
	JS7	+5,0 -5,0	+6,0 -6,0	+7,5 -7,5	+9,0 -9,0	+10,5 -10,5	+12,5 -12,5	+15,0 -15,0	+17,5 -17,5	+20,0 -20,0								
	K7	0 -10	+3 -9	+5 -10	+6 -12	+6 -15	+7 -18	+9 -21	+10 -25	+12 -28								
	N7	-4 -14	-4 -16	-4 -19	-5 -23	-7 -28	-8 -33	-9 -39	-10 -45	-12 -52								
	P7	-6 -16	-8 -20	-9 -24	-11 -29	-14 -35	-17 -42	-21 -51	-24 -59	-28 -68								
h7	h7	0 -10	0 -12	0 -15	0 -18	0 -21	0 -25	0 -30	0 -35	0 -40								
	H8	+14 0	+18 0	+22 0	+27 0	+33 0	+39 0	+46 0	+54 0	+63 0								
h8	h8	0 -14	0 -18	0 -22	0 -27	0 -33	0 -39	0 -46	0 -54	0 -63								
	E9	+39 +14	+50 +20	+61 +25	+75 +32	+92 +40	+112 +50	+134 +60	+159 +72	+185 +85								
	H8	+14 0	+18 0	+22 0	+27 0	+33 0	+39 0	+46 0	+54 0	+63 0								

<i>Uložení</i>	<i>Charakteristika</i>	<i>Příklad</i>
<i>H11 / d11</i>	<i>Uložení se zaručenou vůlí pro součásti s velkými tolerancemi</i>	<i>Odnímatelné páky, táhla</i>
<i>H7 / f7</i>	<i>Uložení s menší vůlí pro součásti, které je třeba vyrobit s větší přesností</i>	<i>Posuvné objímky, ložiska přístrojů, kluzná ložiska</i>
<i>H7 / g6</i>	<i>Uložení s malou vůlí pro součásti vyrobené se značnou přesností</i>	<i>Hydraulické písty, vedení ventilů</i>
<i>H7 / js6</i>	<i>Přechodné uložení s nepatrnou vůlí nebo přesahem pro součásti pojištěné proti otáčení, které se musí často rozebrat</i>	<i>Ruční kolečka, oběžná kola čerpadel</i>
<i>H7 / k6</i>	<i>Přechodné uložení pro součásti, které se dají složit nebo rozebrat mírným tlakem</i>	<i>Lícované šrouby, kroužky přístrojových ložisek</i>
<i>H7 / p6 H7 / r6</i>	<i>Uložení s přesahem – součásti se dají složit nebo rozebrat zastudena velkým tlakem nebo zatepla</i>	<i>Věnce ozubených kol</i>
<i>H7 / s6</i>	<i>Uložení s velkým přesahem – součásti se dají složit zastudena mocným tlakem nebo zatepla</i>	<i>Součásti vyráběné z několika částí – zděře</i>



## ZPŮSOBY ZAPISOVÁNÍ TOLEROVANÝCH ROZMĚRŮ

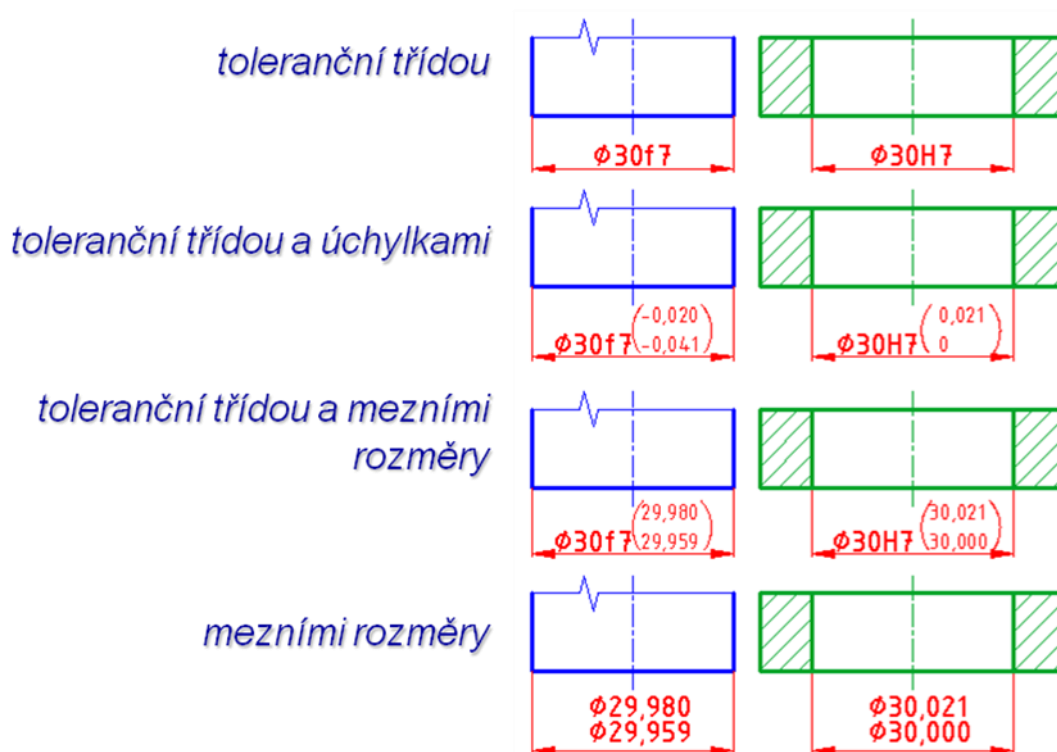

## PŘÍKLADY ZÁPISU TOLERANCÍ

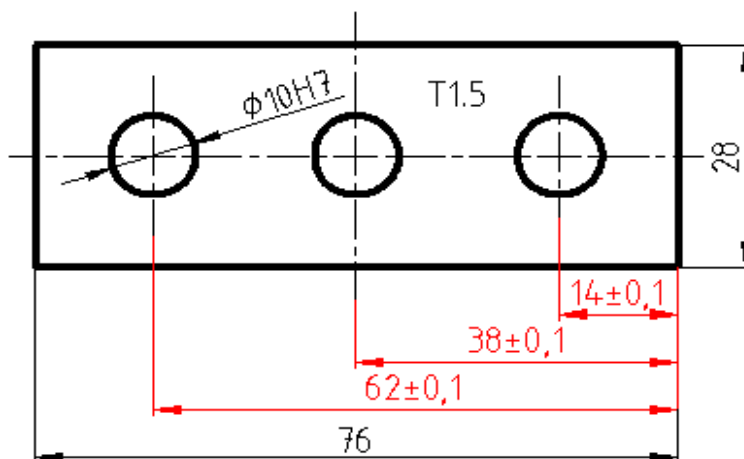
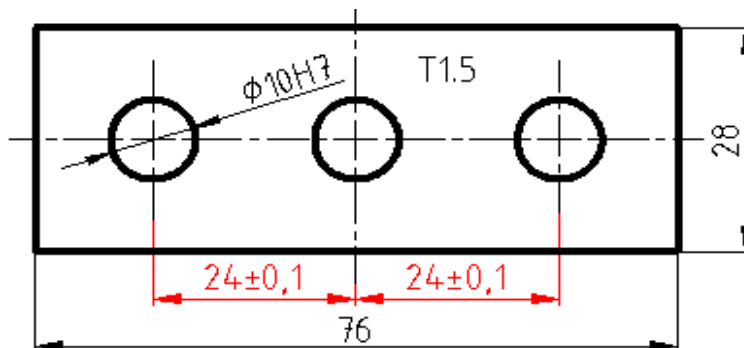





# **CVIČENÍ 9**

## **ŠROUBOVÉ SPOJE**

# ŠROUBOVÉ SPOJE

*vnitřní závit*

*vnější závit*

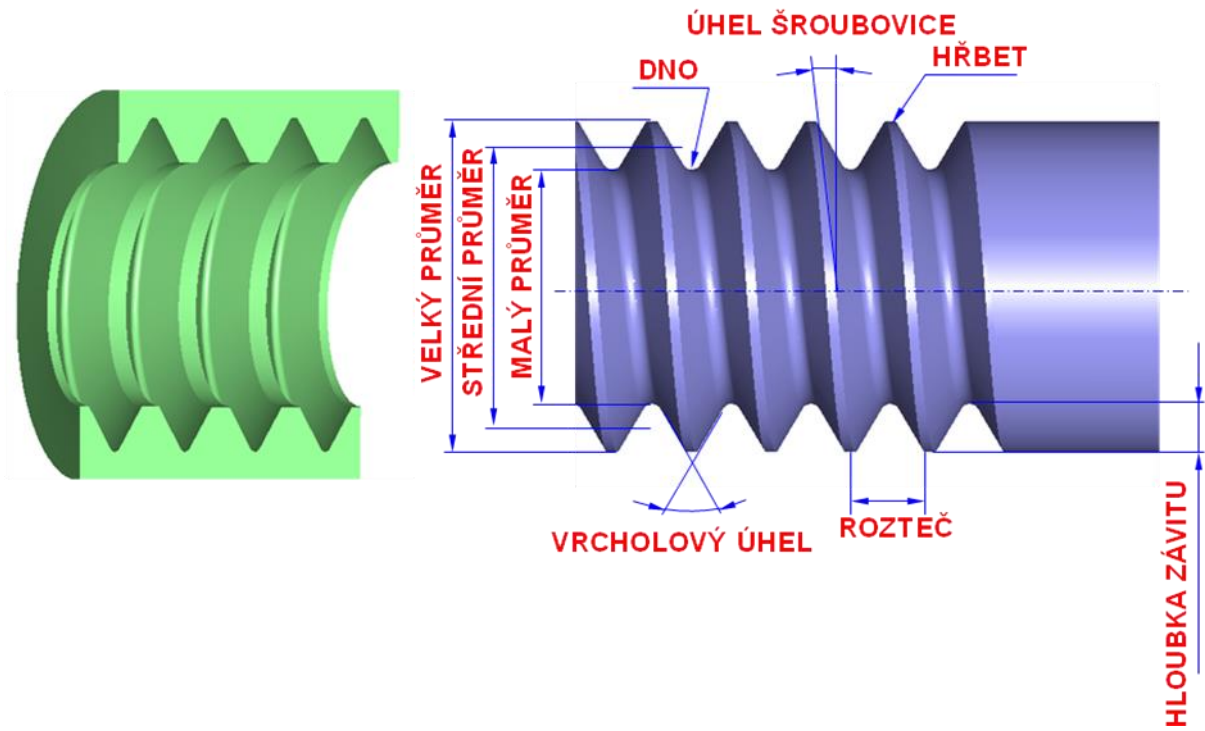

*levý závit*

*pravý závit*

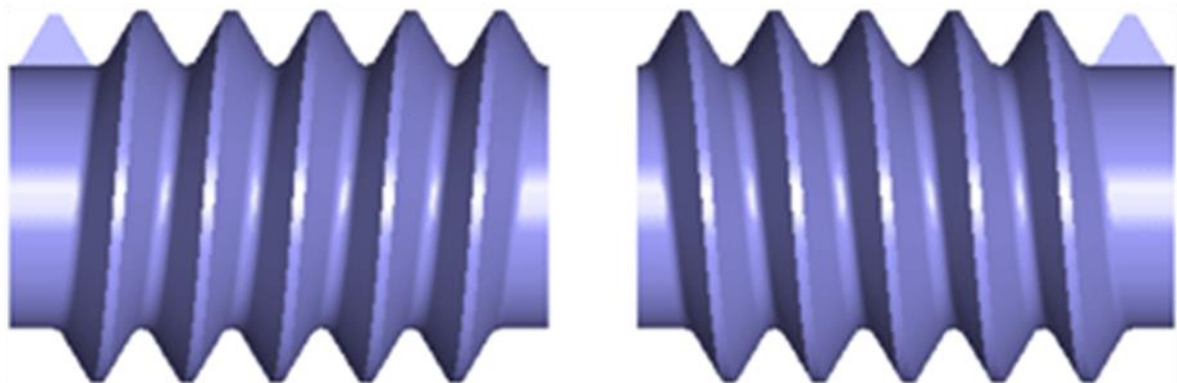

*jednochodý závit*

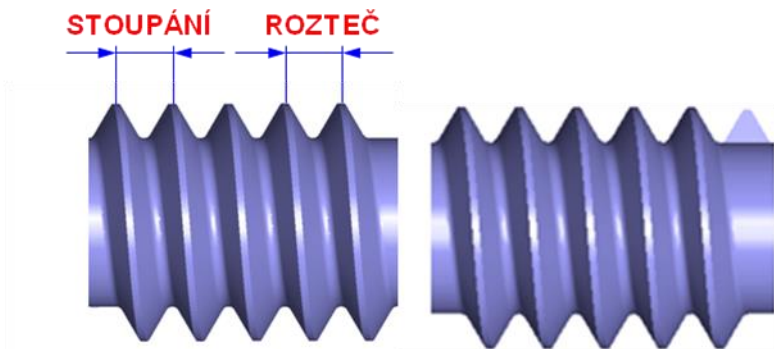

*dvouchodý závit*

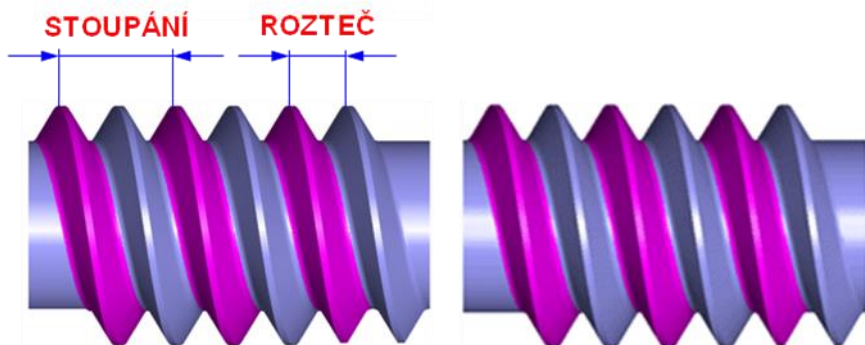

*trojchodý závit*

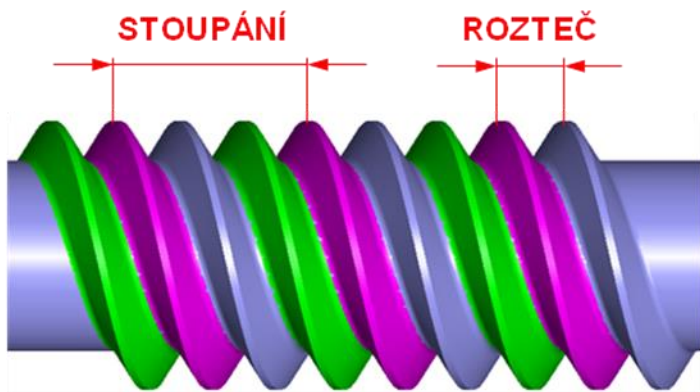

## NORMALIZOVANÉ ZÁVITY – METRICKÝ ZÁVIT

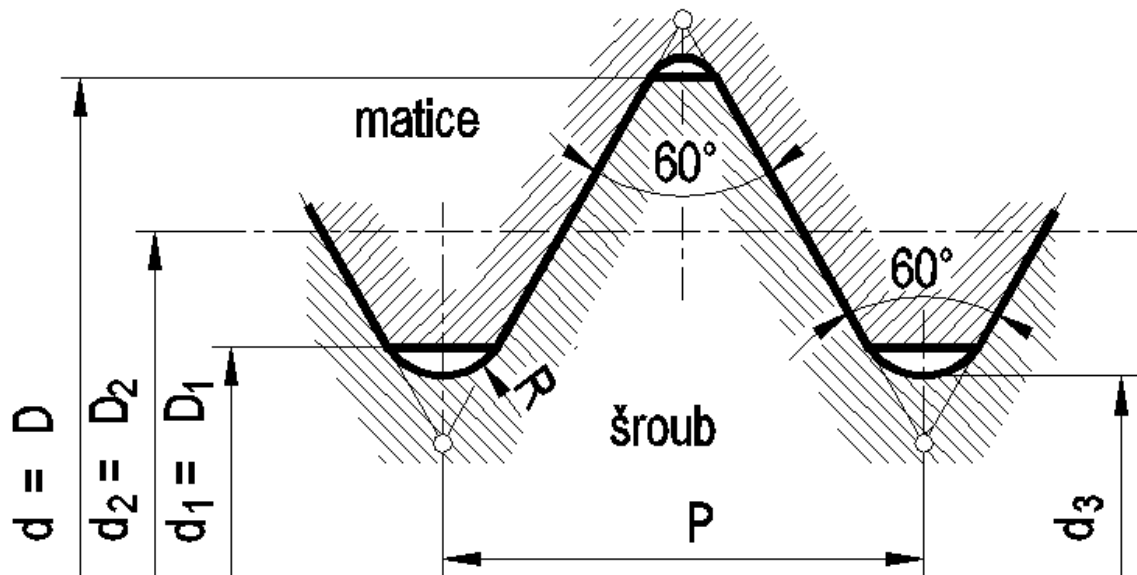
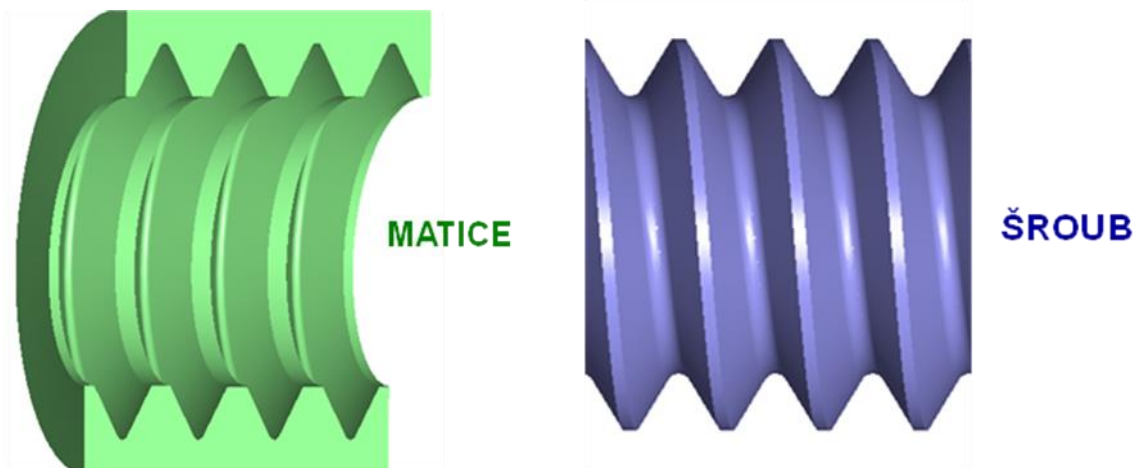

### ZNAČENÍ

závit se základní roztečí:

**$M d$** ,  $d$  ... velký průměr závitu šroubu v mm

závit s jemnou roztečí:

**$M d \times P$** ,  $P$  ... rozteč v mm

**Příklady:**

**$M 3, M 4, M 5, M 6, M 8, M 10, M 12, \dots$**

**$M 10 \times 0.75, M 12 \times 1, \dots$**

## NORMALIZOVANÉ ZÁVITY – WHITWORTHŮV ZÁVIT

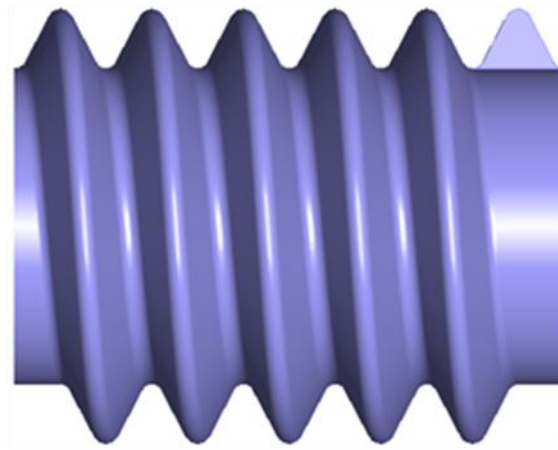

ŠROUB

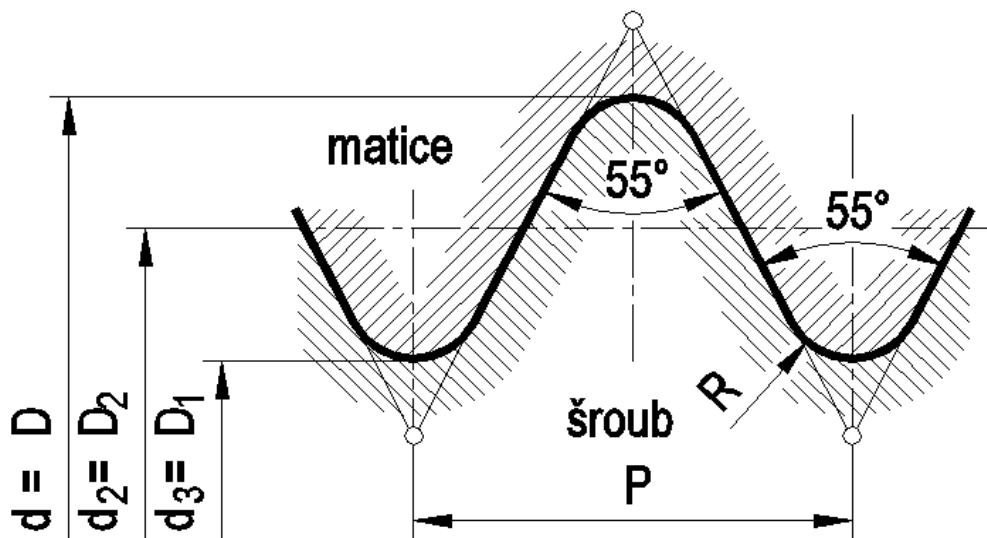

### ZNAČENÍ:

**W** **d**, **d** ... velký průměr závitu šroubu v palcích

### Příklady:

**W<sup>1/4</sup>"**, **W<sup>3/8</sup>"**, **W<sup>1/2</sup>"**, **W<sup>3/4</sup>"**, **W1"**, **W1<sup>1/4</sup>"**, **W1<sup>1/2</sup>"**, **W2"**, ...

## NORMALIZOVANÉ ZÁVITY – TRUBKOVÝ ZÁVIT

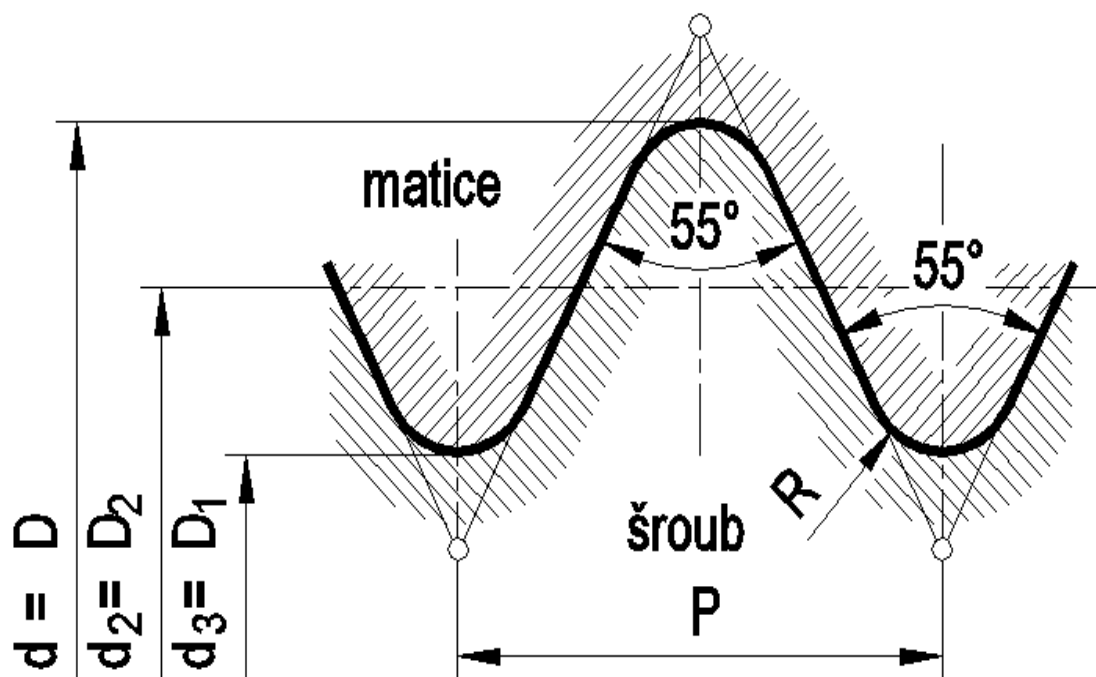
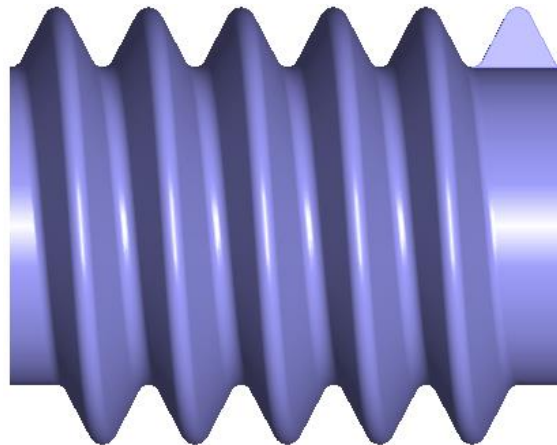

### ZNAČENÍ:

válcový - netěsnící: **G d**

válcový vnitřní - těsnící: **Rp d**

kuželový vnitřní - těsnící: **Rc d**

kuželový vnější - těsnící: **R d**

$d$  ... jmenovitý vnitřní průměr trubky v palcích

### Příklady:

**G $\frac{3}{8}$ "**, **G $\frac{1}{2}$ "**, **G $\frac{3}{4}$ "**, **G1"**, **G1 $\frac{1}{4}$ "**, **G1 $\frac{1}{2}$ "**, **G2"**, ...

## NORMALIZOVANÉ ZÁVITY – EDISONŮV ZÁVIT

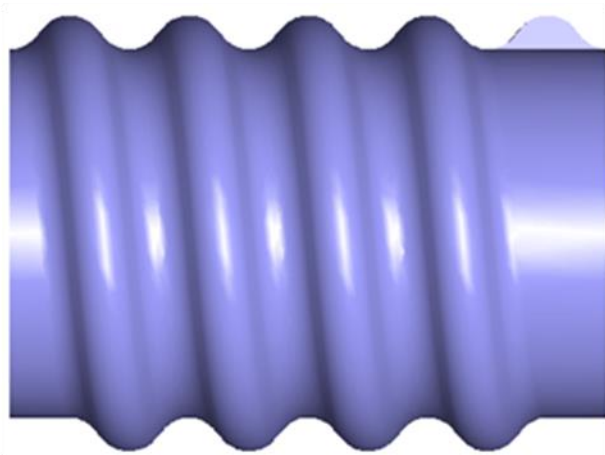

ŠROUB

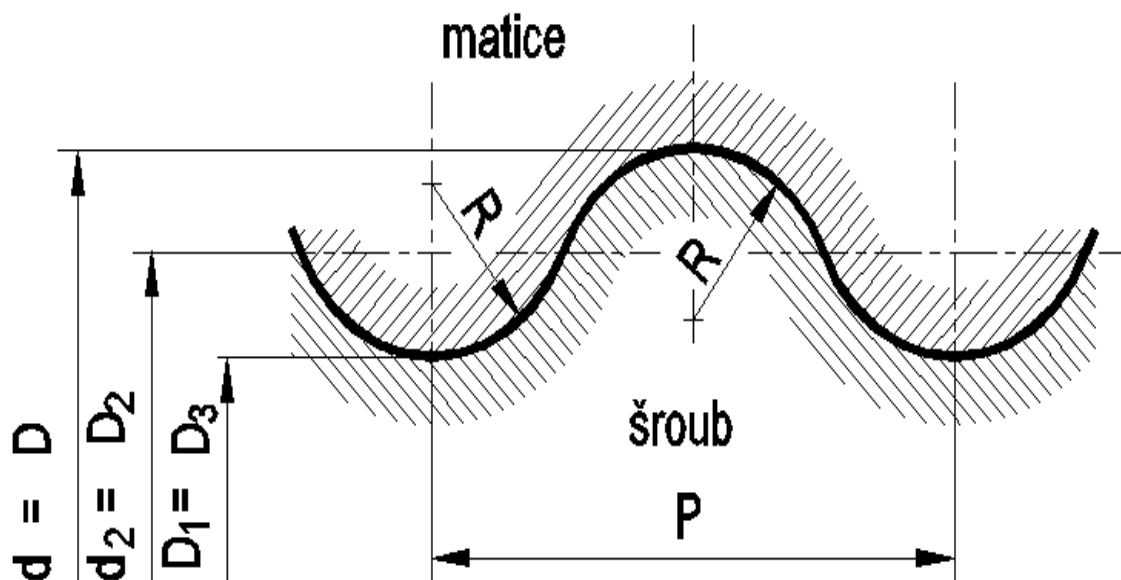

### ZNAČENÍ:

**E d** ,  $d$  ... velký průměr závitu v mm

### Příklady:

**E10** „trpasličí“ (v ručních svítilnách)

**E14** „miňon“ (pro malá svítidla)

**E27** standardní velikost (klasické žárovky, výbojky)

**E33** „goliáš“ (velké žárovky a výbojky např. v pouličním osvětlení)



## NORMALIZOVANÉ ZÁVITY – PANCÉŘOVÝ ZÁVIT

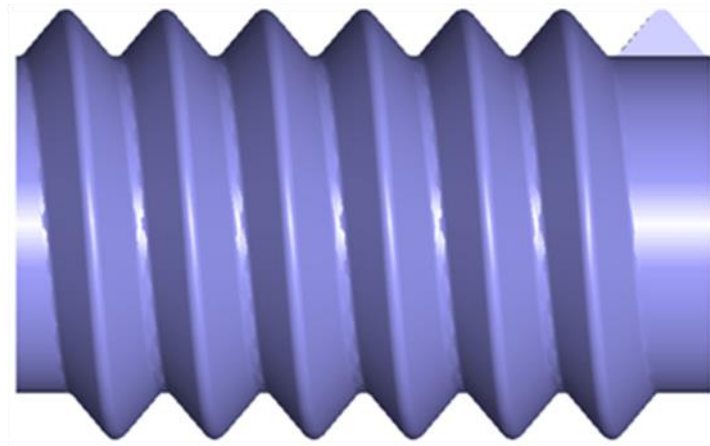

ŠROUB

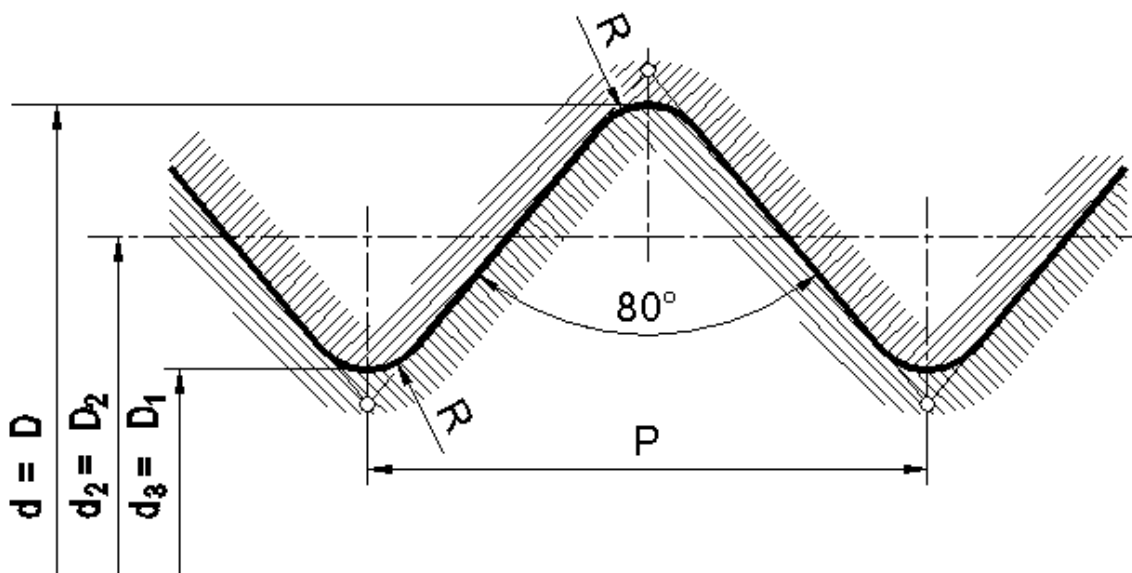

### ZNAČENÍ:

**P**  $d$ ,  $d$  ... jmenovitý vnitřní průměr trubky v mm

### Příklady:

**P11, P13.5, P16, P21, P29, P36, ...**



## NORMALIZOVANÉ ZÁVITY – LICHOBĚŽNÍKOVÝ ROVNORAMENNÝ ZÁVIT

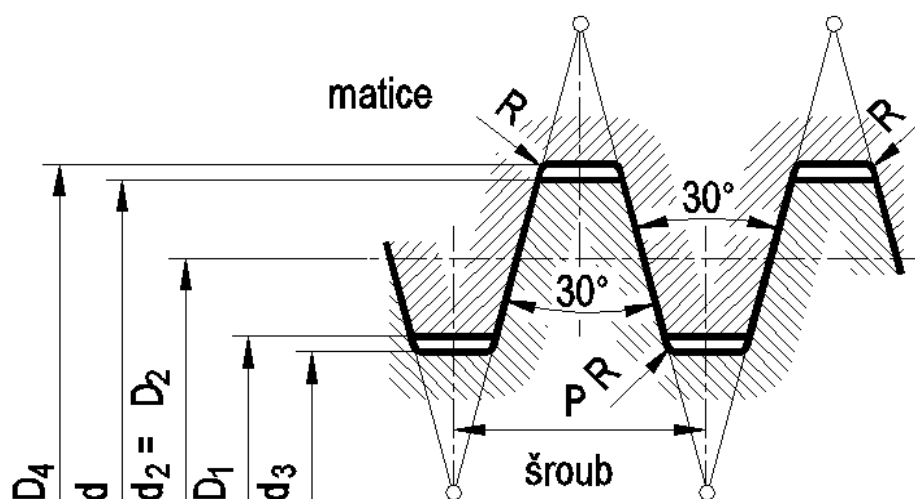
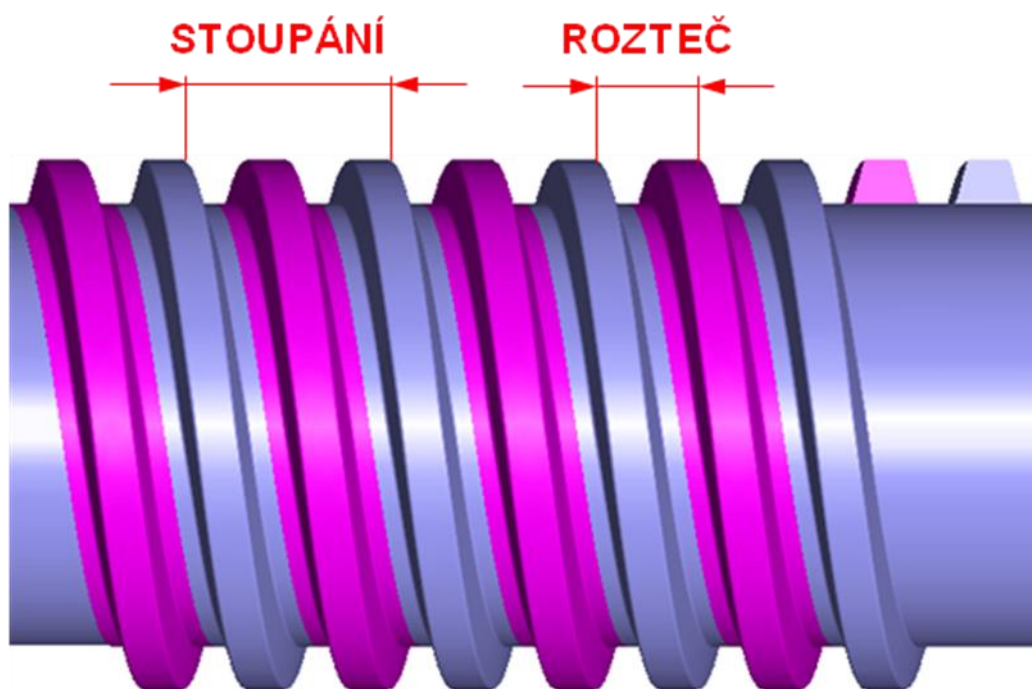

### ZNAČENÍ:

jednochodý: **Trd x S**

d ... velký průměr závitu šroubu v mm

S ... stoupání v mm

### Příklady:

jednochodý závit: **Tr 10 x 3, Tr 16 x 4, Tr 20 x 4, Tr 30 x 6, ...**

vícechodý závit: **Trd x S (P)**

P ... rozteč v mm

**Příklady: Tr 50 x 16 (P8) ... dvouchodý**

*vnější závit*

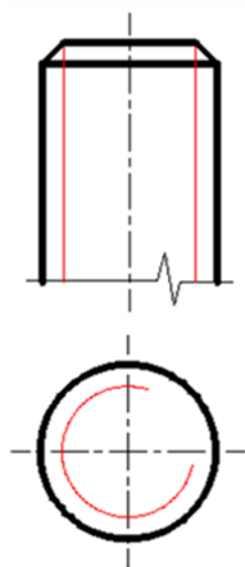

*vnitřní závit*

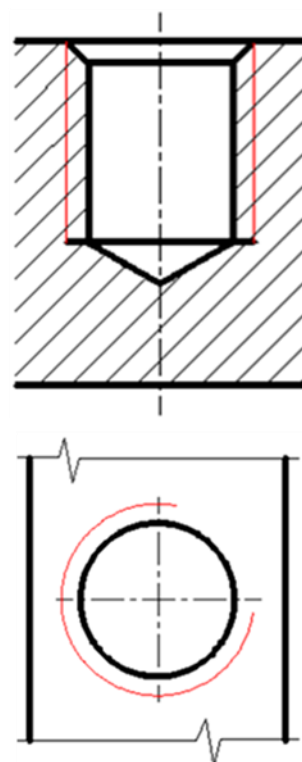
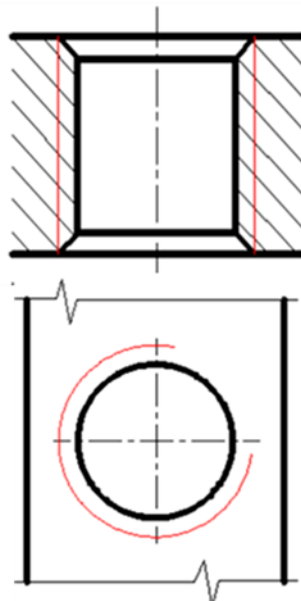

*vnější závit*

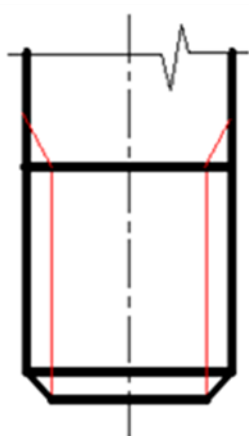
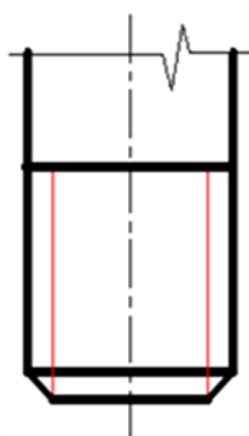

**VÝBĚH**

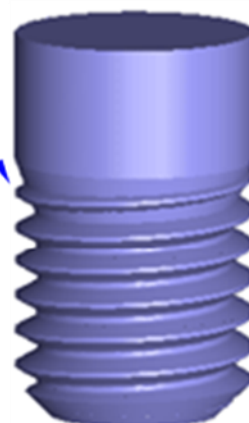

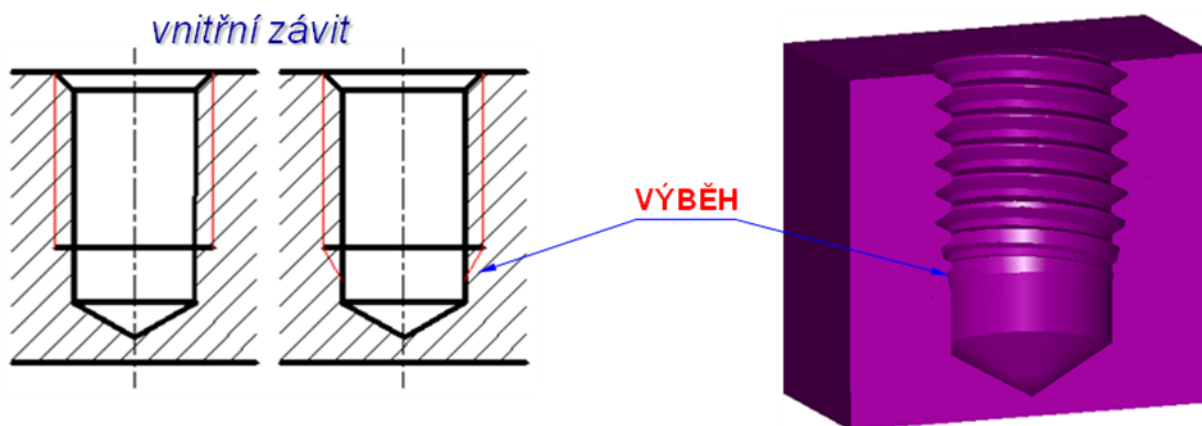

### KÓTOVÁNÍ ZÁVITŮ

vnější závit

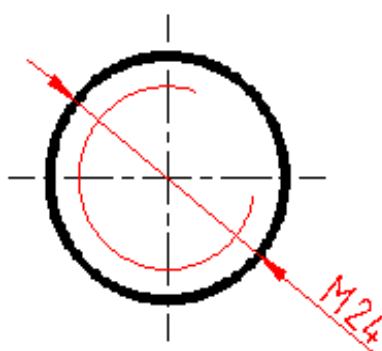
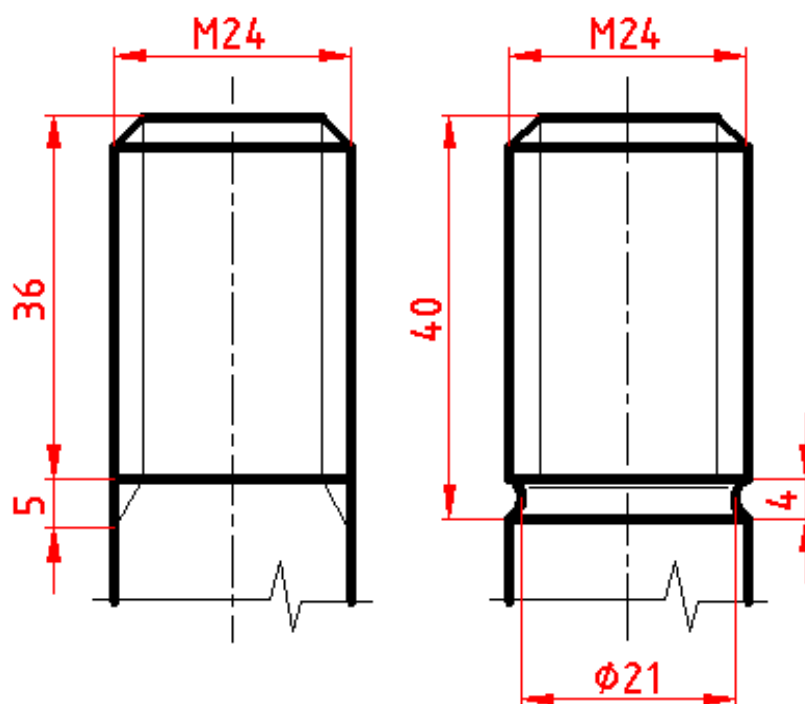

## vnitřní závit

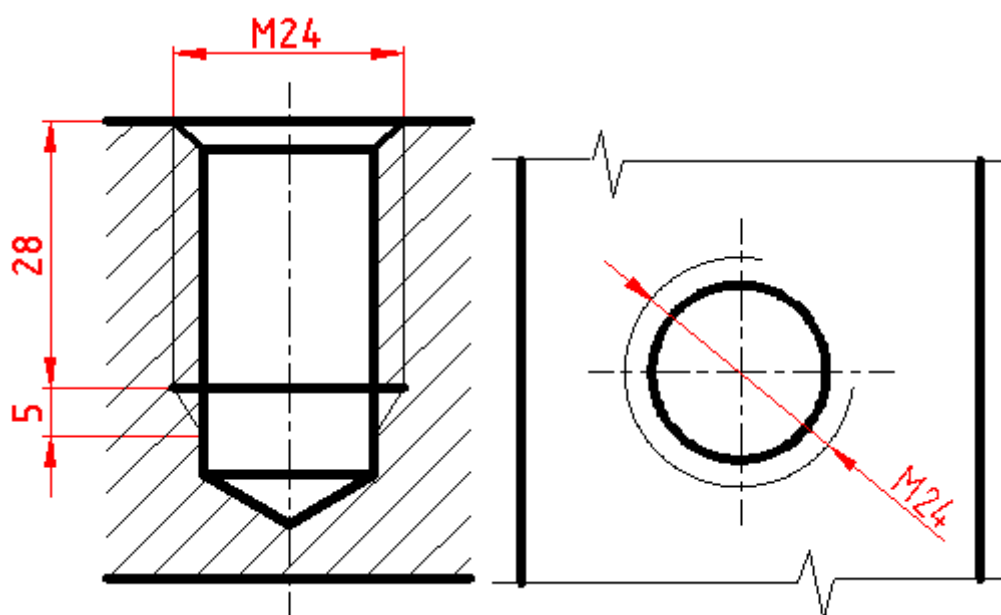

## NENORMALIZOVANÝ ZÁVIT – KRESLENÍ A KÓTOVÁNÍ

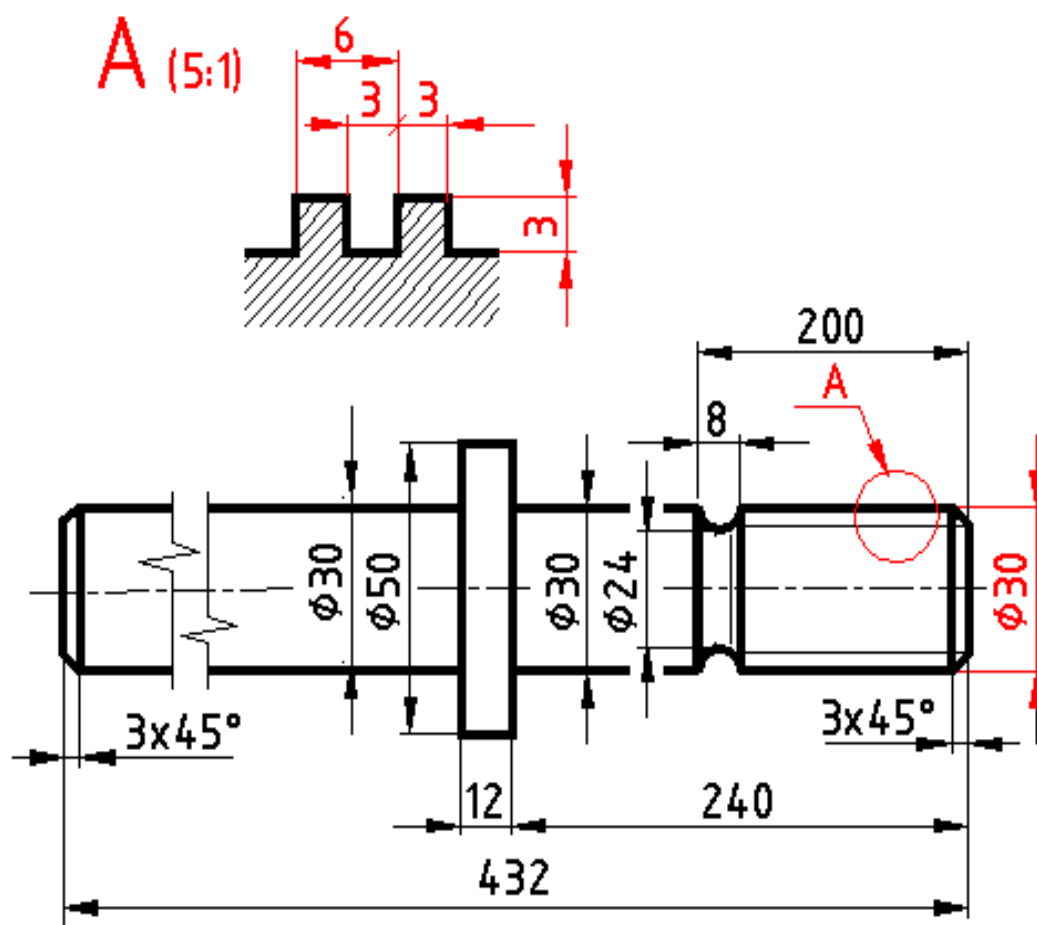

## ŠESTIHRANNÉ MATICE A HLAVY ŠROUBŮ – MÉNĚ PŘESNÉ KRESLENÍ

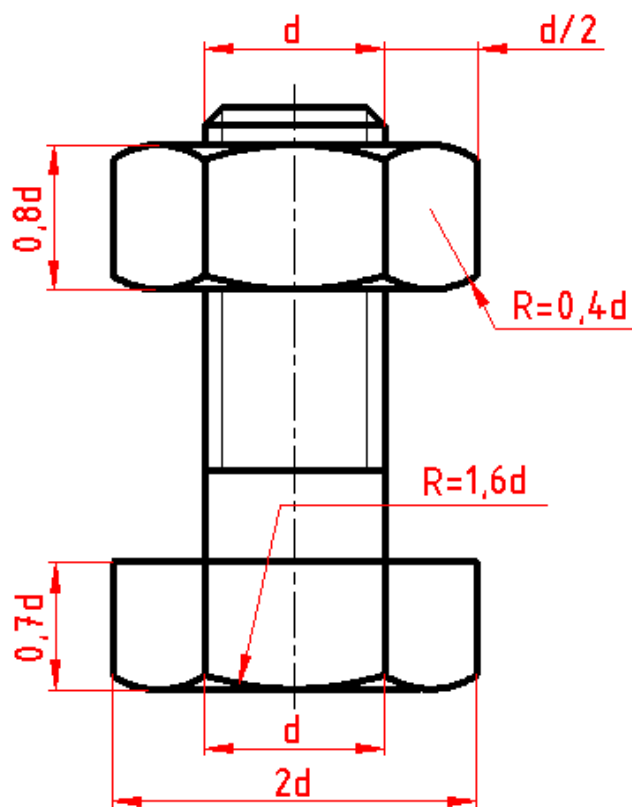
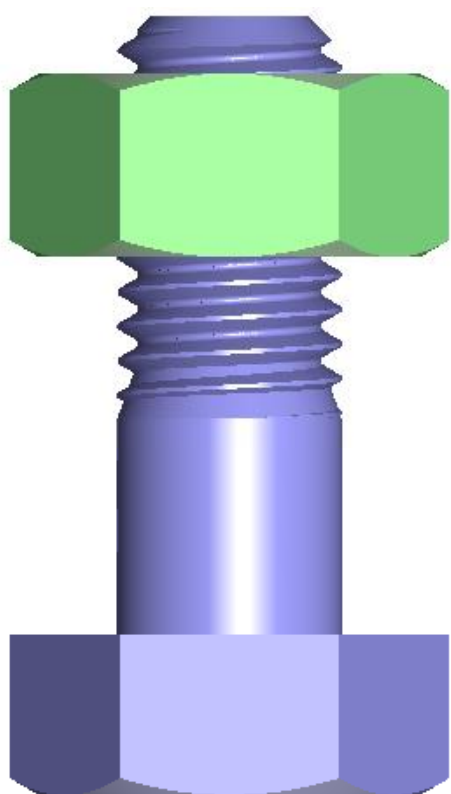

## ŠESTIHRANNÉ MATICE A HLAVY ŠROUBŮ – PŘESNĚJŠÍ KRESLENÍ

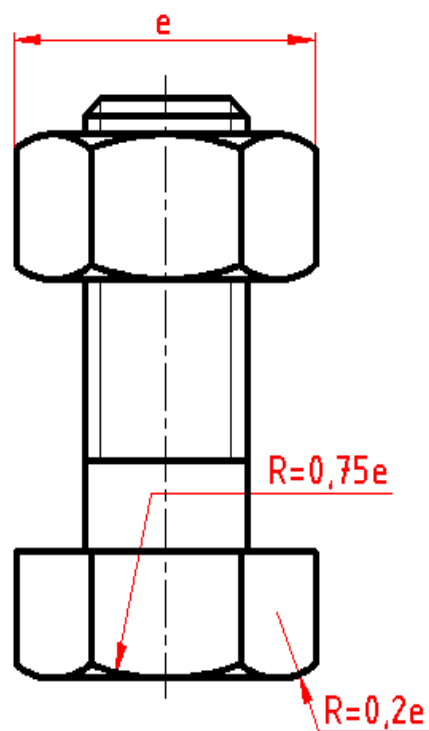
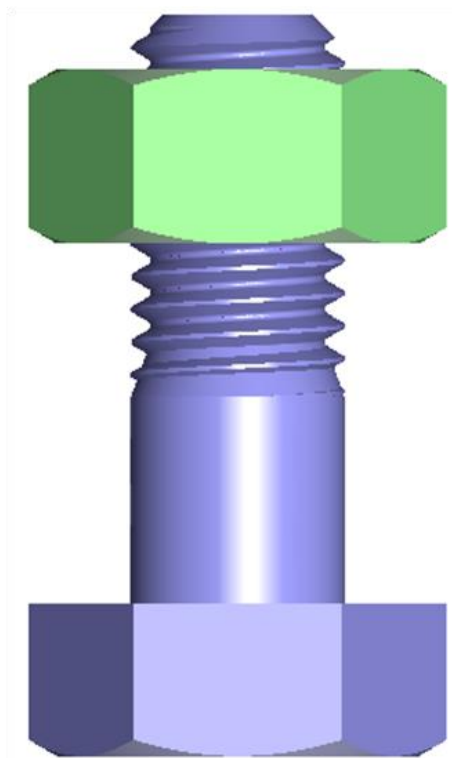

# KRESLENÍ ZÁVITOVÝCH SPOJŮ NA VÝKRESECH SESTAVENÍ

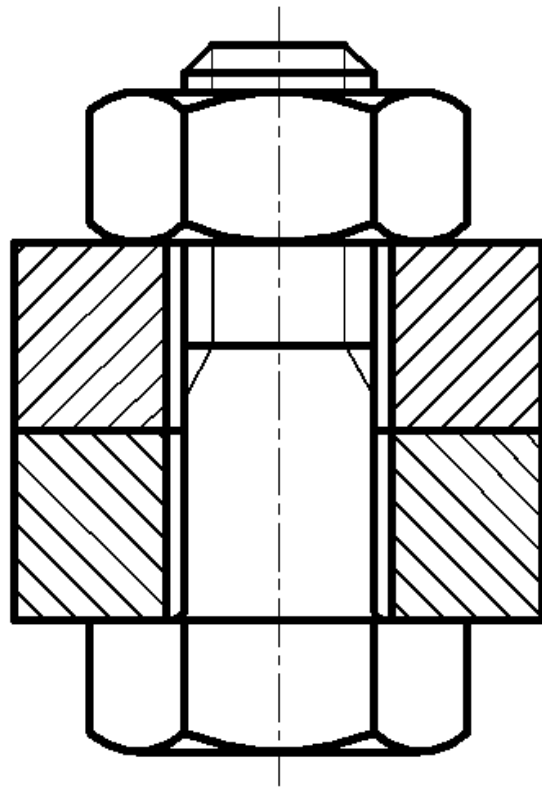
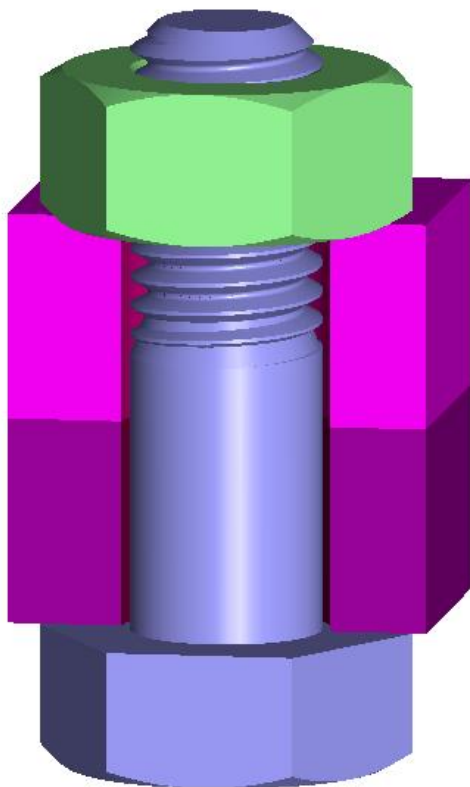
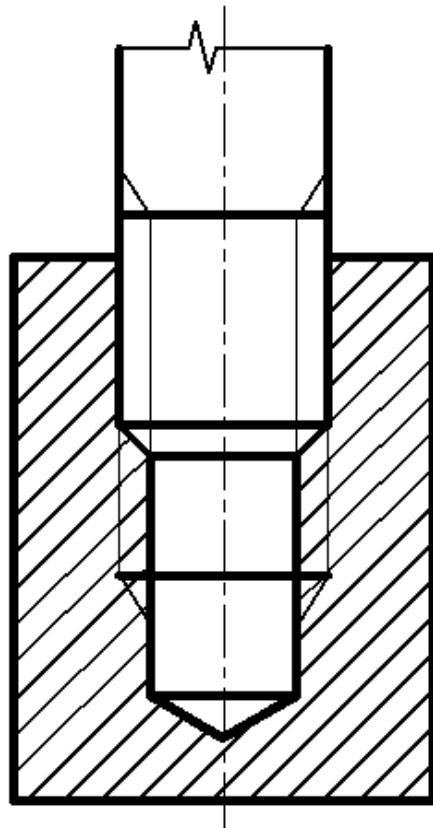
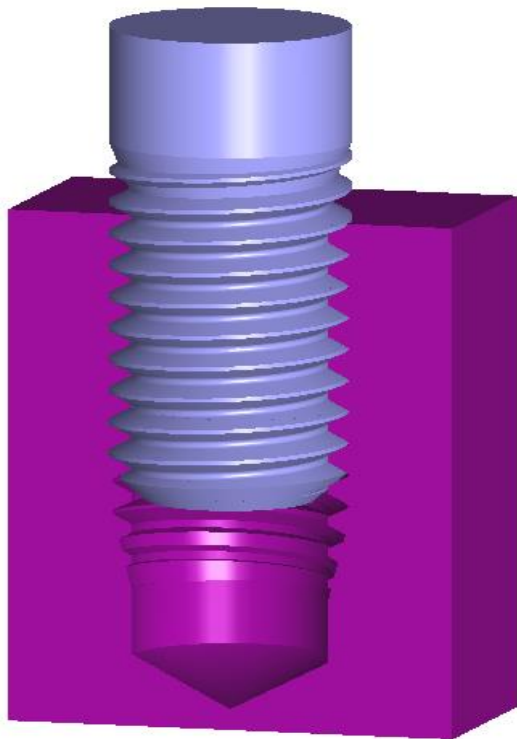

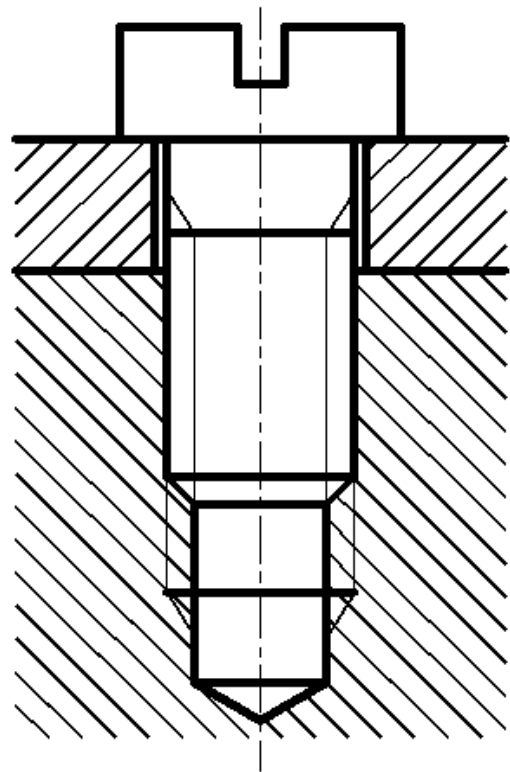
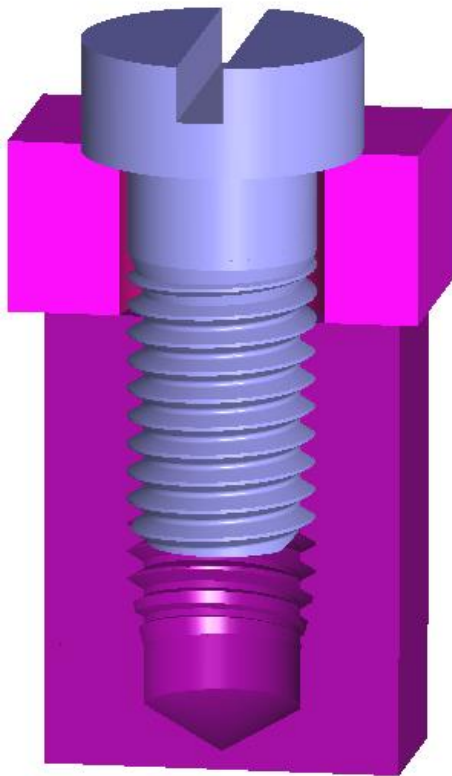
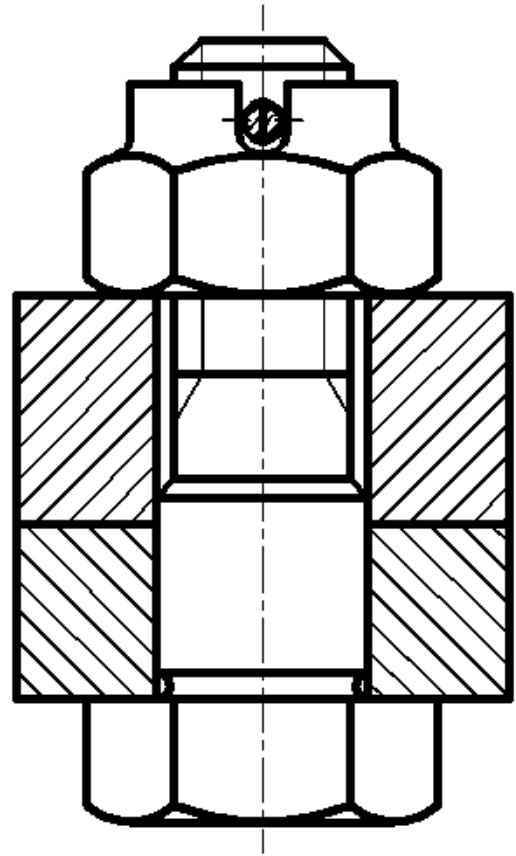
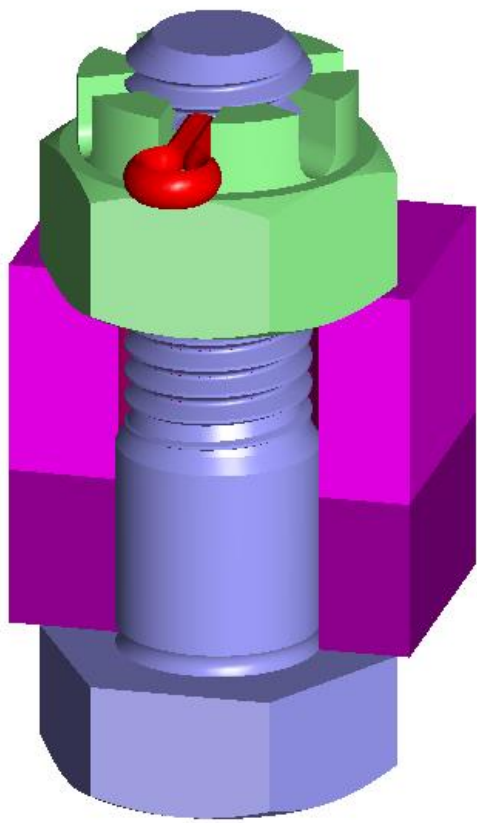

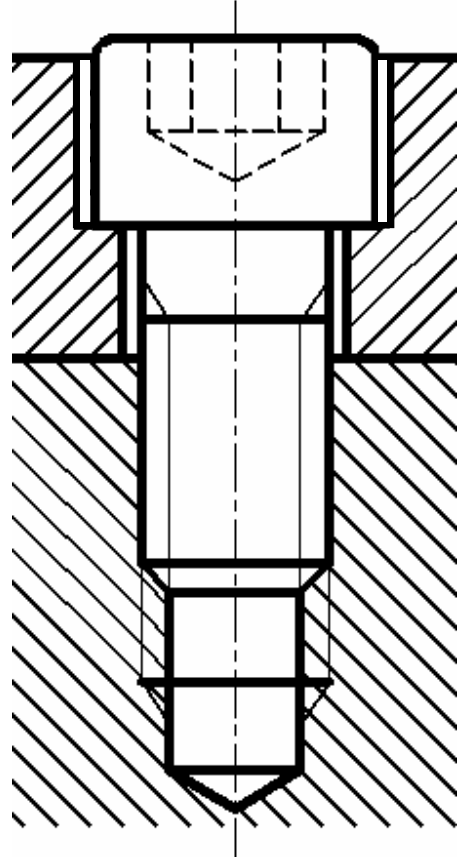
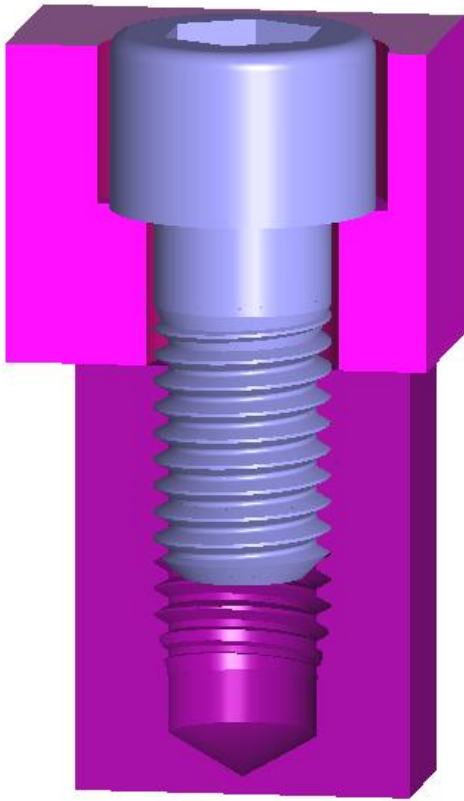
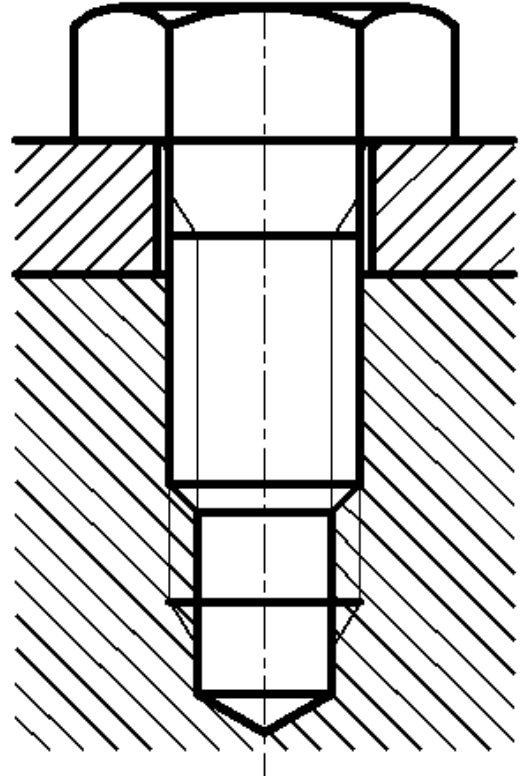
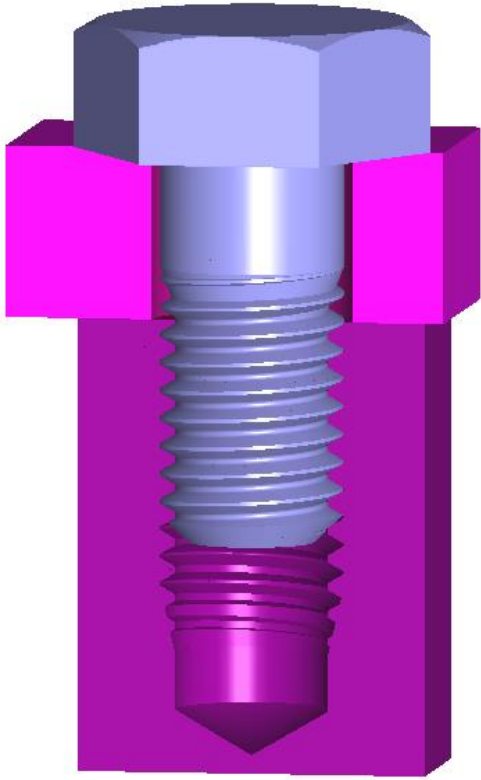



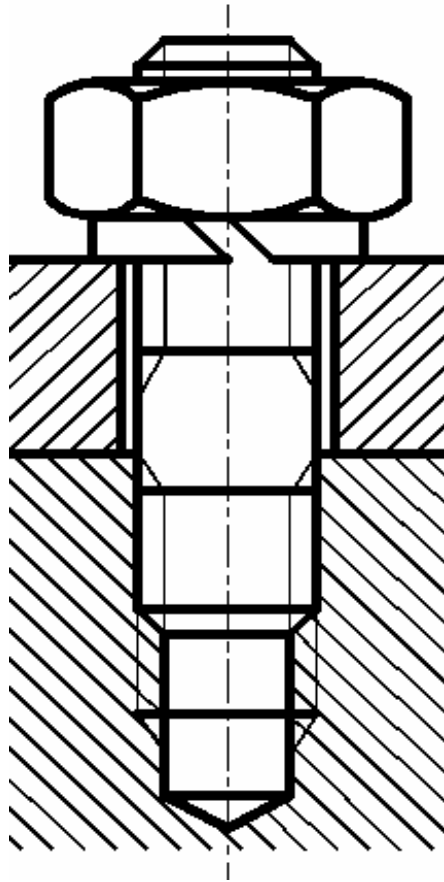
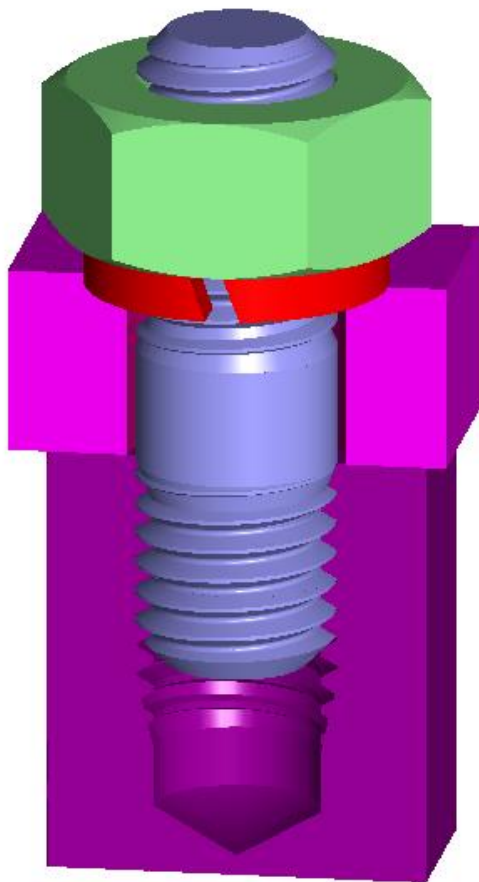
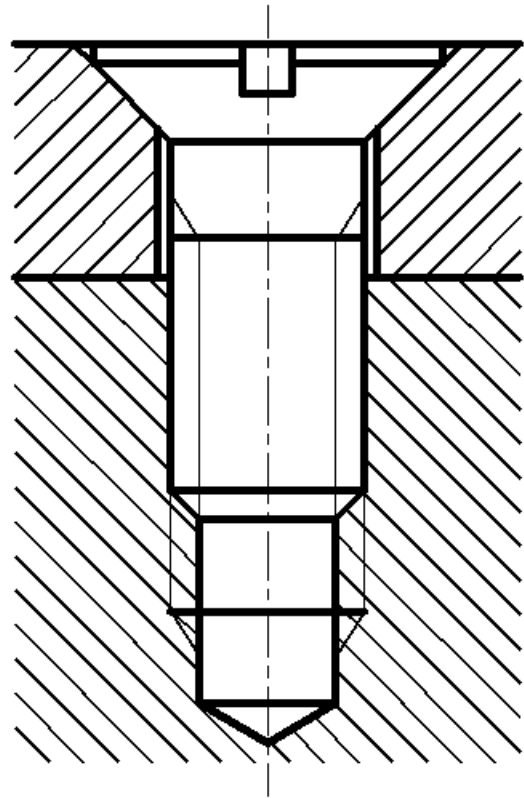
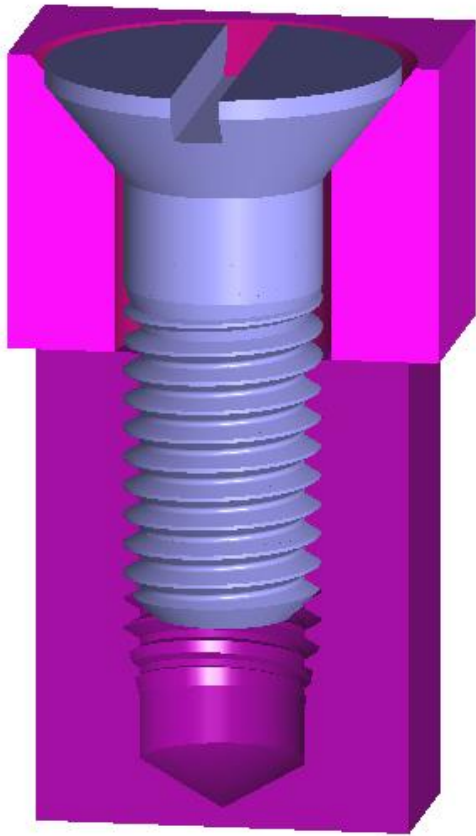

## **CVIČENÍ 10**

**NÝTOVÉ SPOJE, PÁJENÉ SPOJE, SVAROVÉ  
SPOJE**

# NÝTOVÉ SPOJE

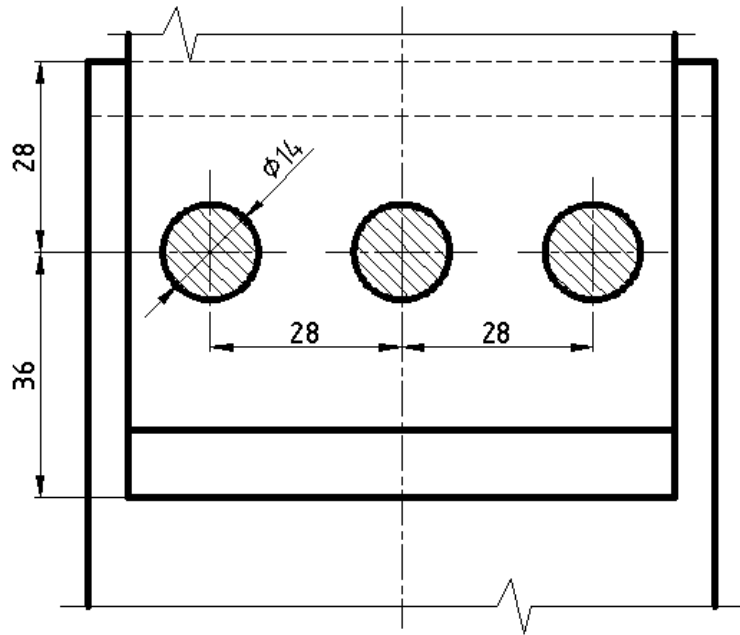
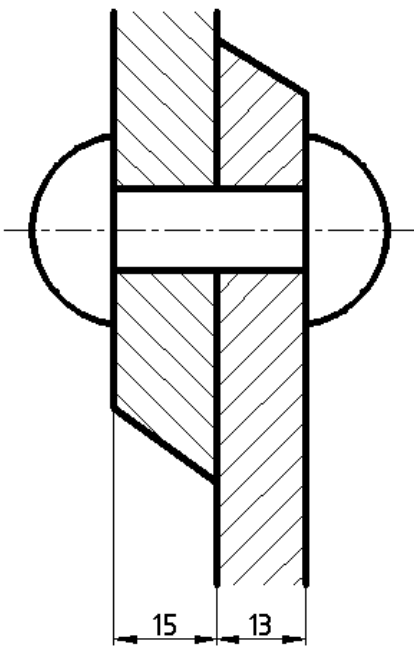
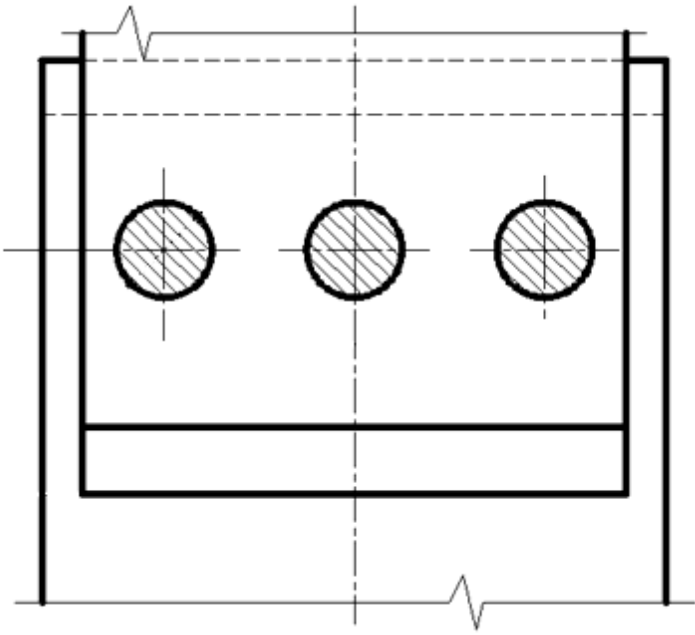
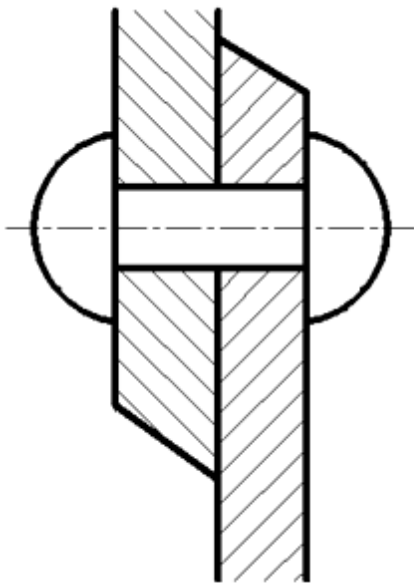

## PÁJENÉ SPOJE

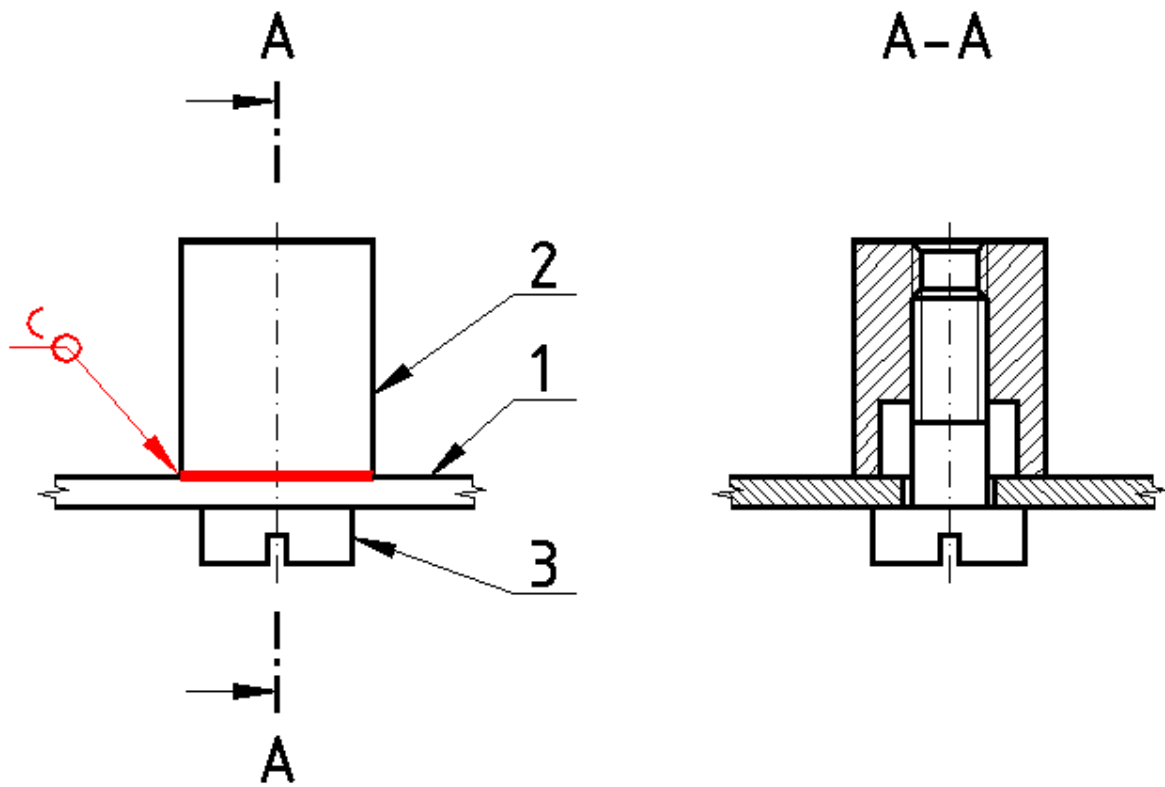

STŘEDÍCÍ ŠROUB M3x12 PO PŘIPÁJENÍ DÍLU 2 ODSTRANIT

## SVAROVÉ SPOJE – TUPÝ V SVAR

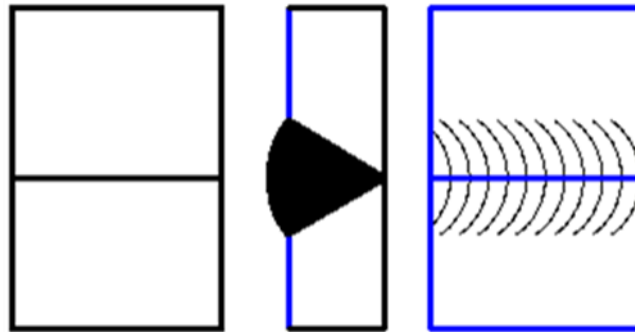

•Kótování svaru – směr promítání je kolmý na tupý svar

Svar je na téže straně, odkud vychází odkazová čára

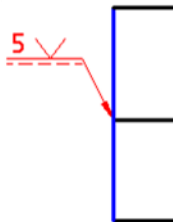

Svar je na opačné straně, než odkud vychází odkazová čára

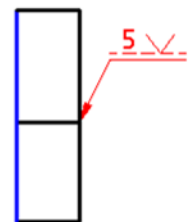

•Kótování svaru – směr promítání je rovnoběžný s tupým svarem

Svar je na téže straně, odkud vychází odkazová čára

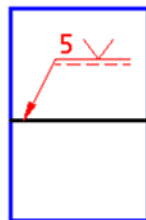

Svar je na opačné straně, než odkud vychází odkazová čára



## SVAROVÉ SPOJE – KOUTOVÝ SVAR

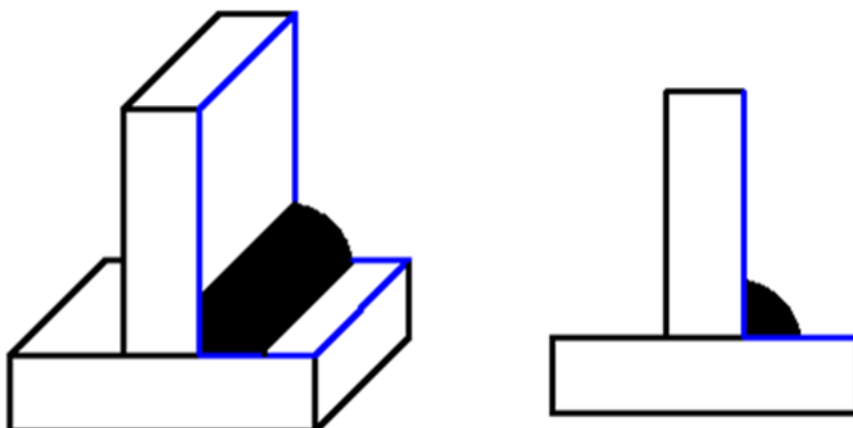

•Kótování svaru – směr promítání je kolmý na koutový svar

Svar je na téže straně, odkud vychází odkazová čára

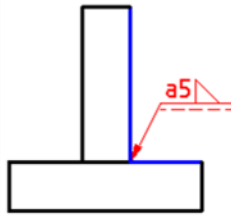

Svar je na opačné straně, než odkud vychází odkazová čára

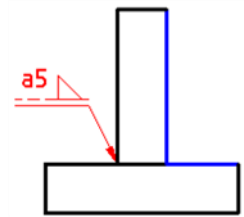

•Kótování svaru – směr promítání je rovnoběžný s koutovým svarem

Svar je na téže straně, odkud vychází odkazová čára



Svar je na opačné straně, než odkud vychází odkazová čára

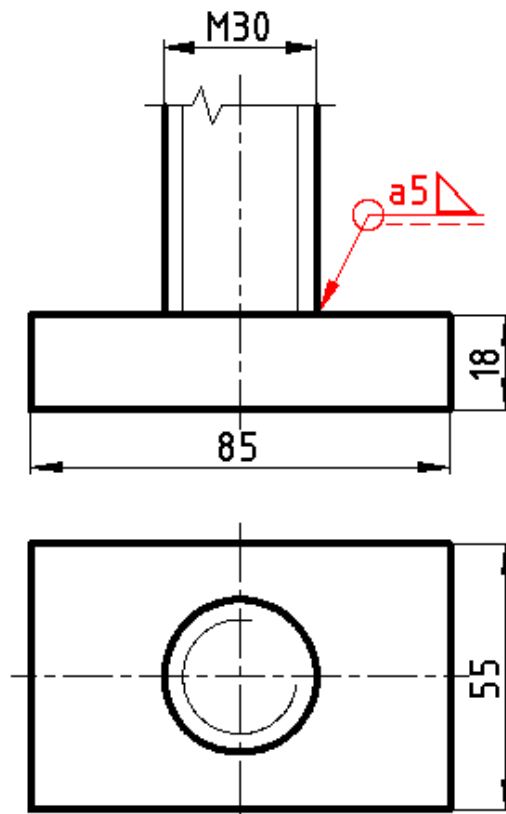
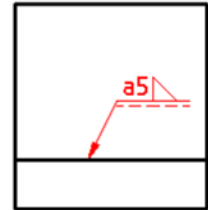

## **CVIČENÍ 11**

**LOŽISKA, PERA, KLÍNY, PRUŽINY**

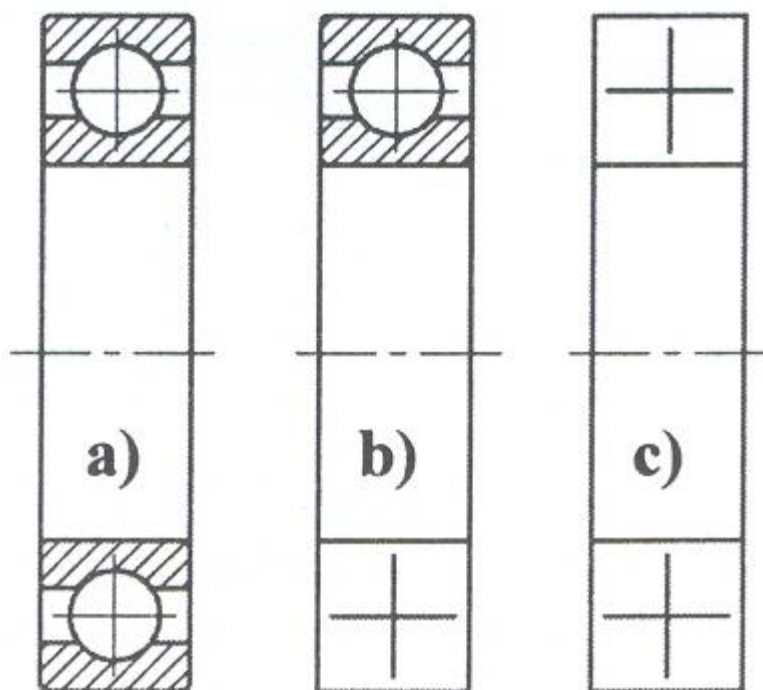
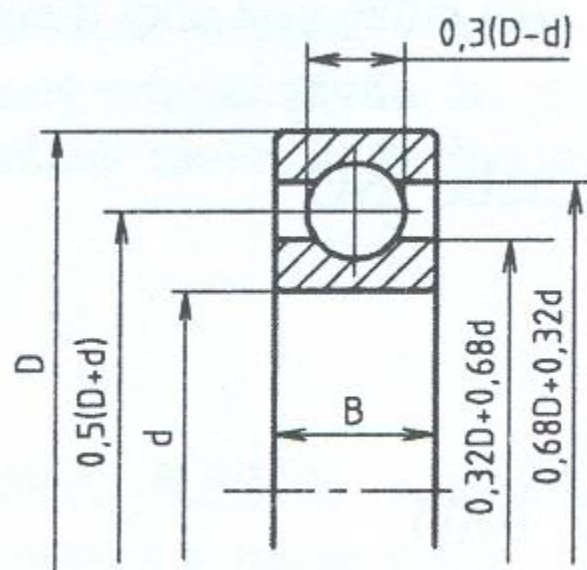

a) zjednodušené      b) smíšené  
 c) schematické (není vhodné pro  
 použití na návrhovém výkrese)



# KLÍNY

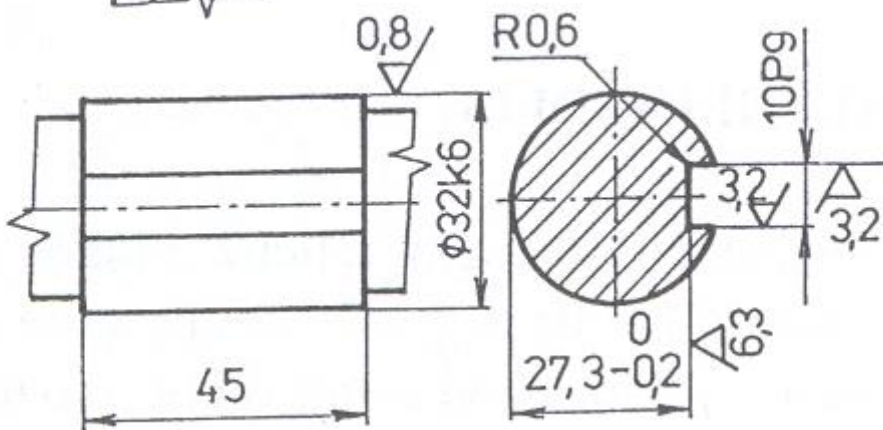
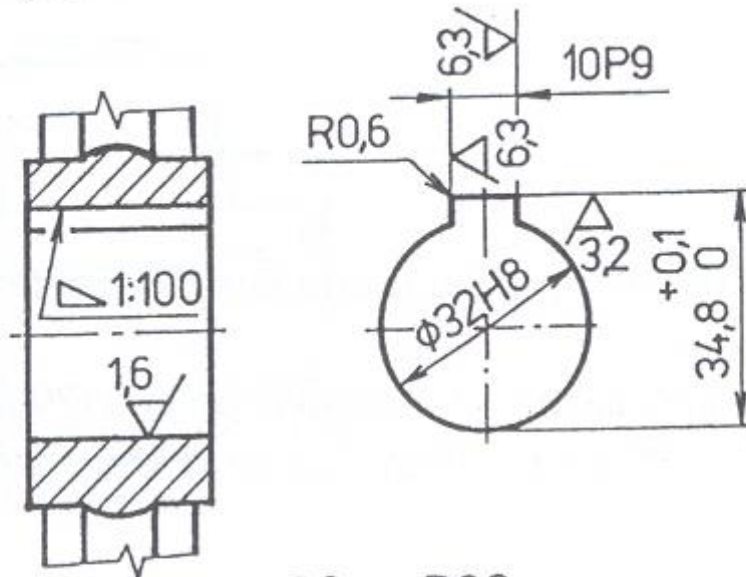
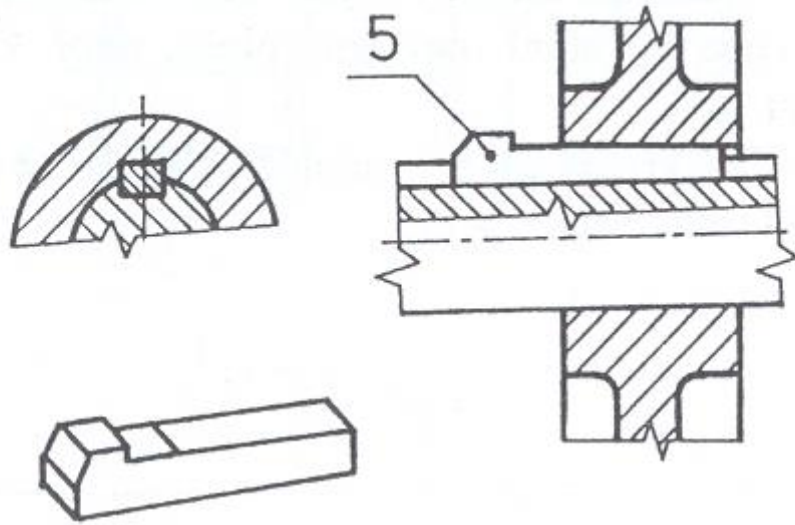

# PERA

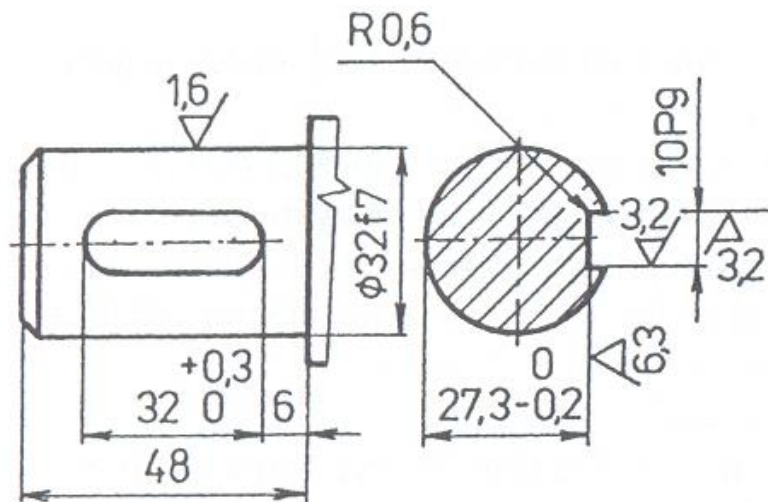
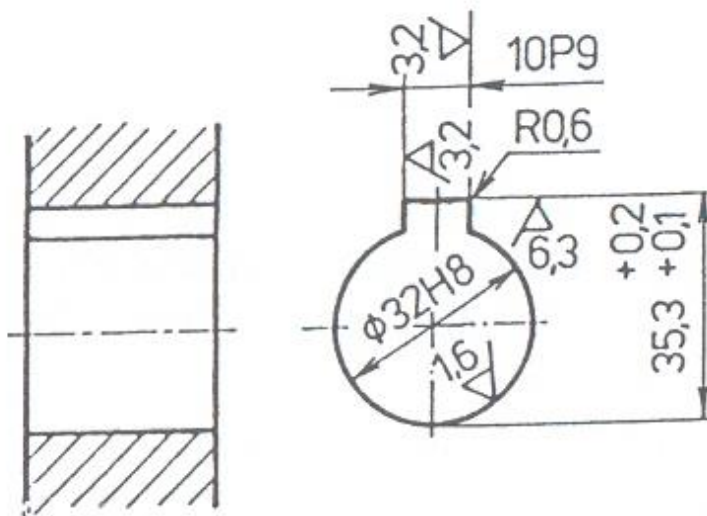
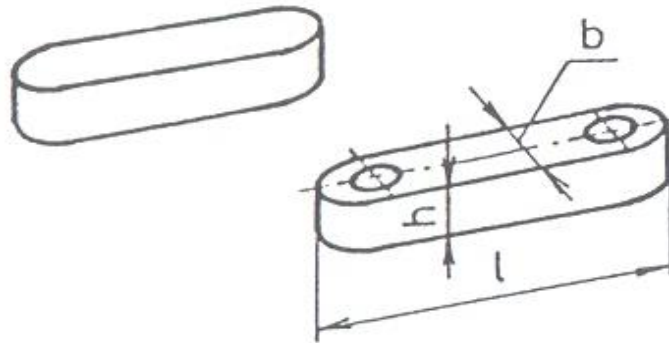
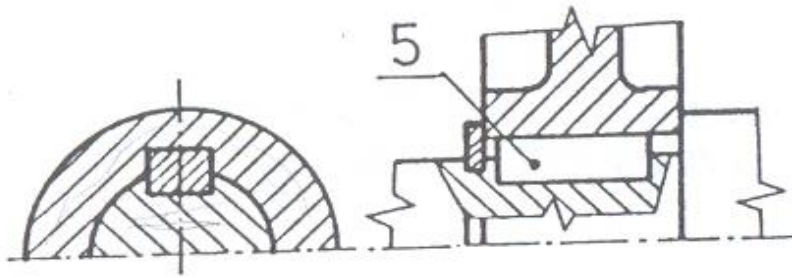

# PRUŽINY

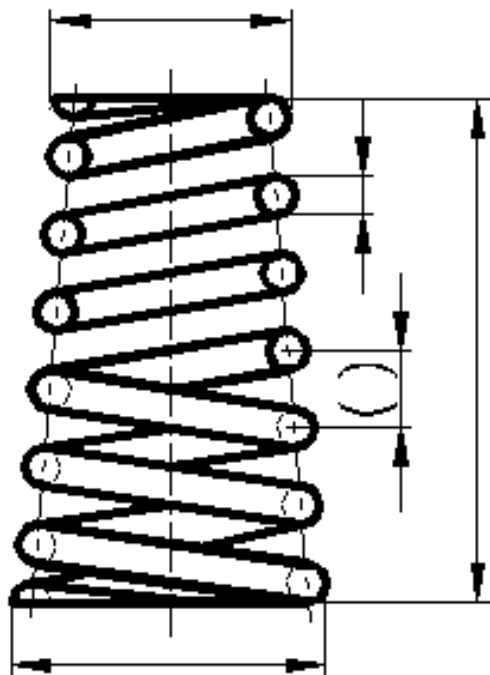
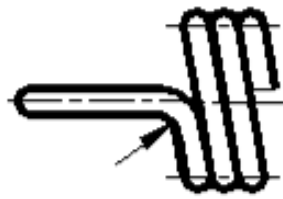
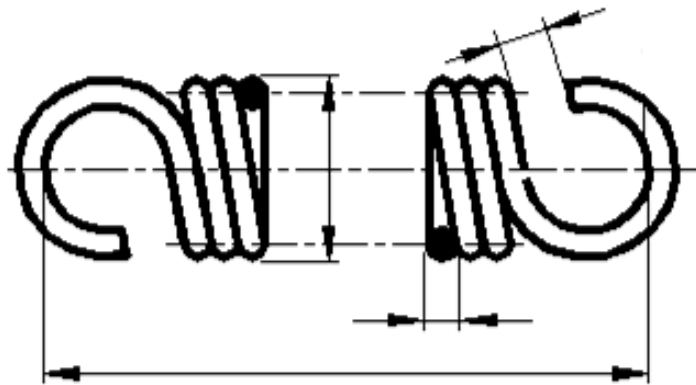

## **CVIČENÍ 12**

### **ELEKTROTECHNICKÉ ZNAČKY**

## ELEKTROTECHNICKÉ ZNAČKY

všeobecná

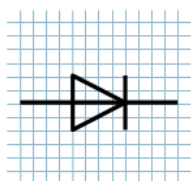

doplňková

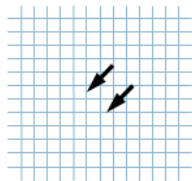

podrobná

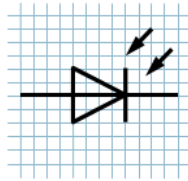

bloková

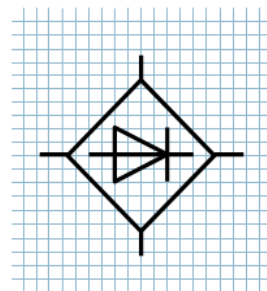

polovodičová dioda

neionizující záření

fotodioda

místkový  
usměrňovač

spojení vodičů  
s odbočením

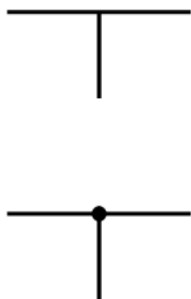

spojení vodičů se  
dvěma odbočeními

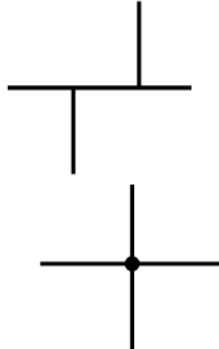

vodiče spojeny  
nejsou

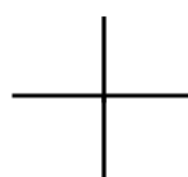

**VIDLICE (KOLÍK) A  
ZÁSUVKA  
PLUG AND SOCKET  
(MALE AND FEMALE)**



**SVORKA**  
kroužek může být vyplněn  
**TERMINAL**  
the circle may be filled in

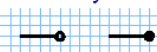

**ZAP. KONTAKT, SPÍNAČ  
MAKE CONTACT**

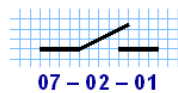

07 - 02 - 01

**VYPÍNAČÍ KONTAKT  
BREAK CONTACT**

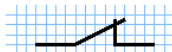

**PŘEPÍNAČÍ KONTAKT  
v klidové poloze sepnutý  
CHANGE-OVER  
CONTACT**

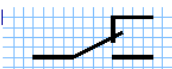

**PŘEPÍNAČÍ KONTAKT  
se střední klidovou polohou  
TWO-WAY CONTACT  
with centre-off position**

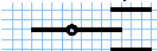

**OVLÁDACÍ ÚSTROJÍ  
(CÍVKA RELÉ)  
všeobecná značka  
OPERATING DEVICE  
(COIL OF RELAY)  
general symbol**

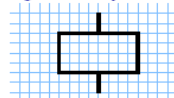

**REZISTOR  
všeobecná značka  
RESISTOR  
general symbol**

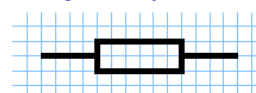

**REZISTOR  
NASTAVITELNÝ  
nástrojem  
ADJUSTABLE RESISTOR  
by tool**

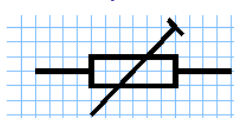

**POTENCIOMETR  
s pohyblivým kontaktem  
POTENTIOMETER  
with sliding contact**

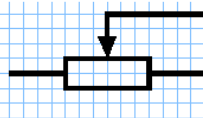

**TERMISTOR  
THERMISTOR**

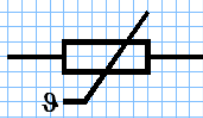

**KONDENZÁTOR  
NEPROMĚNNÝ  
všeobecná značka  
CAPACITOR  
general symbol**



**KONDENZÁTOR  
POLARIZOVANÝ  
POLARIZED  
CAPACITOR**

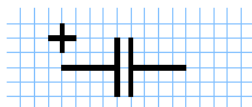

**TAVNÁ POJISTKA  
všeobecná značka  
FUSE  
general symbol**



**KONDENZÁTOR  
NASTAVITELNÝ  
nástrojem  
ADJUSTABLE  
CAPACITOR  
by tool**

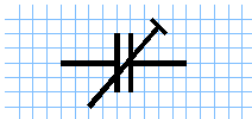

**INDUKTOR, CÍVKA,  
VINUTÍ, TLUMIVKA  
INDUCTOR, COIL,  
WINDING, CHOKE**

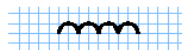

**KONDENZÁTOR  
PROMĚNNÝ  
VARIABLE  
CAPACITOR**

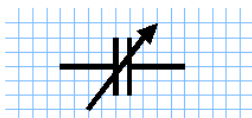

**PIEZOELEKTRICKÁ  
JEDNOTKA  
se dvěma elektrodami  
PIEZOELECTRIC  
CRYSTAL  
with two electrodes**

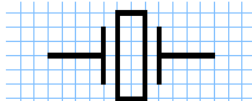

**POLOVODIČOVÁ DIODA  
všeobecná značka  
SEMICONDUCTOR DIODE  
general symbol**

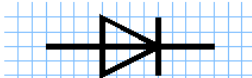

**LUMINISCENČNÍ DIODA  
všeobecná značka  
LIGHT EMITTING DIODE  
general symbol**

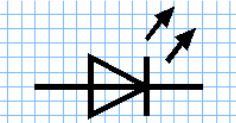

**DIODA S PRŮRAZOVÝM  
JEVEM,  
JEDNO SMĚRNÁ  
NAPĚŤOVÁ DIODA,  
REGULAČNÍ DIODA,  
ZENEROVA DIODA  
BREAKDOWN DIODE,  
UNIDIRECTIONAL  
VOLTAGE DIODE,  
ESAKI DIODE**

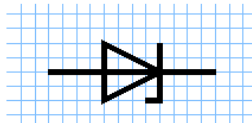

**TRANZISTOR TYPU PNP  
PNP TRANSISTOR**

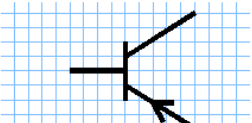

**TRANZISTOR TYPU NPN  
kol. spojený s pouzdem  
NPN TRANSISTOR  
with collector connected  
to the envelope**

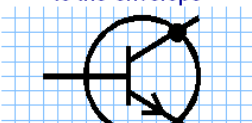

**TRANZISTOR ŘÍZENÝ  
POLEM  
JUNCTION FIELD EFFECT  
TRANSISTOR**

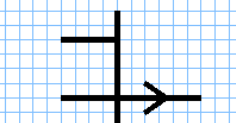

**USMĚRŇOVAČ  
MŮSTKOVÝ V CELÉ VLNĚ  
blokova značka  
RECTIFIER  
IN FULL WAVE (BRIDGE)  
CONNECTION  
block symbol**

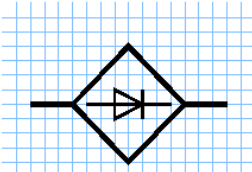

**PRIMÁRNÍ ČLÁNEK  
AKUMULÁTOR  
delší čárka ... kladný pól  
kratší čárka ... záporný pól  
PRIMARY CELL  
ACCUMULATOR  
longer line ... positive pole  
shorter line ... negative pole**

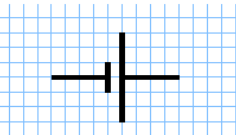

**FOTOTRANZISTOR  
PHOTOTRANSISTOR**



**FOTOELEKTRICKÝ  
ČLÁNEK  
PHOTOVOLTAIC CELL**

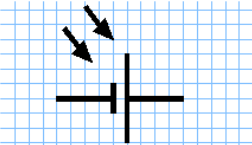

**TRANSFORMÁTOR  
se dvěma vinutími  
TRANSFORMER  
with two windings**

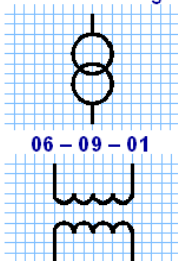

**TRANSFORMÁTOR  
se třemi vinutími  
TRANSFORMER  
with three windings**



**TAVNÁ POJISTKA  
všeobecná značka  
FUSE  
general symbol**



**UKAZOVACÍ  
(voltmetr)  
INDICATING  
(voltmeter)**



**ZAPISOVACÍ  
(wattmetr)  
RECORDING  
(wattmeter)**

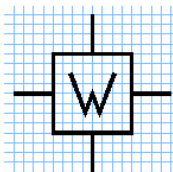

**SVĚTELNÝ ZDROJ,  
SIGNÁLNÍ SVĚTELNÝ  
ZDROJ**  
všeobecná značka  
**LAMP, SIGNAL LAMP**  
general symbol



**MIKROFON  
MICROPHONES**

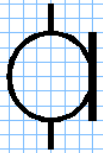

**SLUCHÁTKO  
všeobecná značka  
EARPHONE  
general symbol**



**REPRODUKTOR  
všeobecná značka  
LOUDSPEAKER  
general symbol**

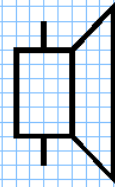

**ANTÉNA  
MAGNETICKOU TYČÍ**  
např. feritovou  
**MAGNETIC ROD  
ANTENNA**  
e.g. ferrite



všeobecná značka  
general symbol



**SKLÁDANÝ DIPÓL  
FOLDED DIPOLE**

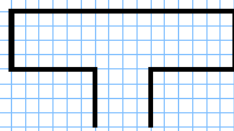

**OPERAČNÍ ZESILOVAČ  
OPERATIONAL  
AMPLIFIER**

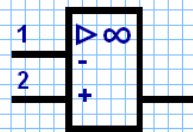

**SOUČINOVÝ PRVEK AND  
AND ELEMENT**

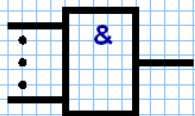

**SOUČTOVÝ PRVEK OR  
OR ELEMENT**

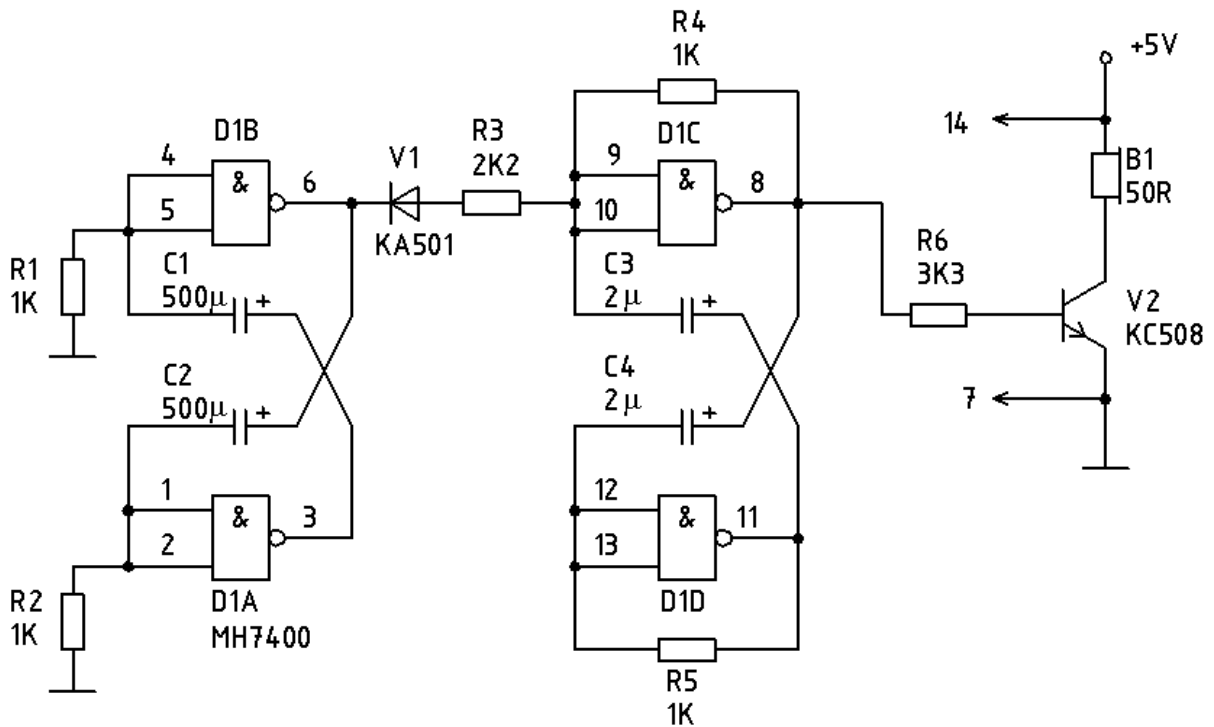
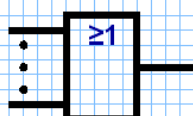

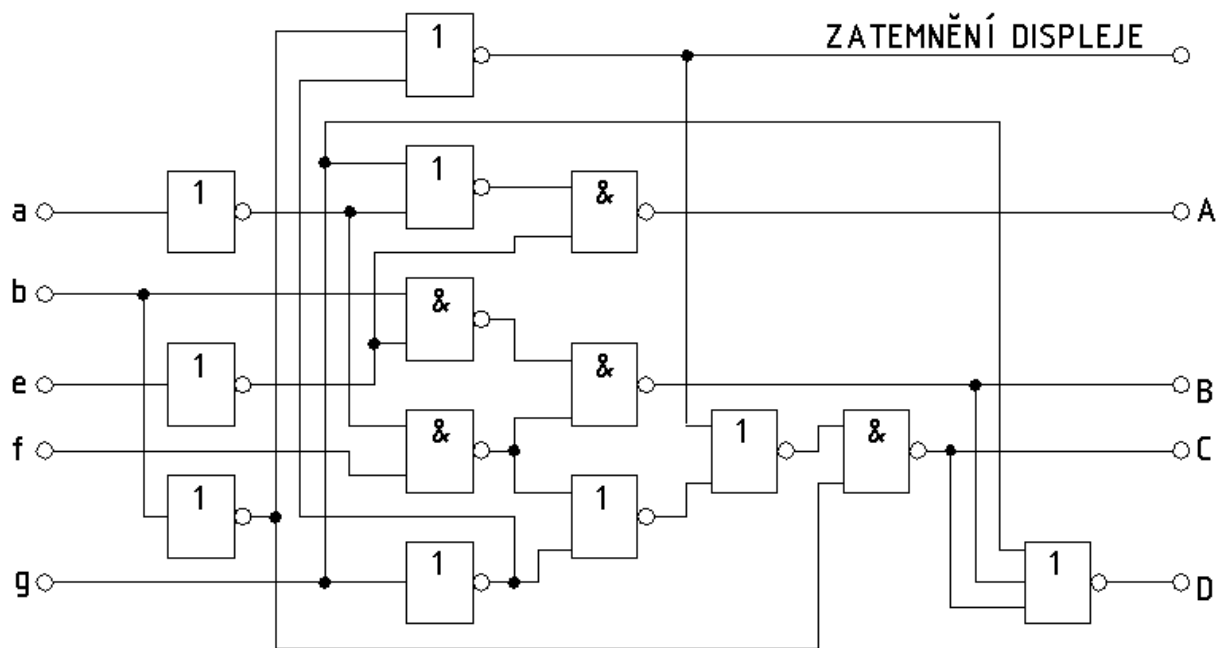

- 1) DRASTÍK, F. *Technické kreslení podle mezinárodních norem I.* 1. vyd. Ostrava, Montanex, 1994. 385 s. ISBN 80-7225-013-2.
- 2) VOJTÍK, J. *Grafická komunikace.* 1 vyd. Praha, SNTL, 1986.
- 3) ŠVEJDA, T. *Technické kreslení.* 3. Vyd Praha, SNTL, 1995. 269 s. ISBN 80-7285-026-8.
- 4) VÁVRA, O. *Strojnické tabulky.* 2. přepracované vyd. Praha, SNTL, 1984. 752 s.
- 5) LINKEOVÁ, I. - NOVÁK, F. *Vybrané partie z technického kreslení.* Dostupné na: <http://marian.fsik.cvut.cz/~linkeova/skripta/skripta.htm>.